

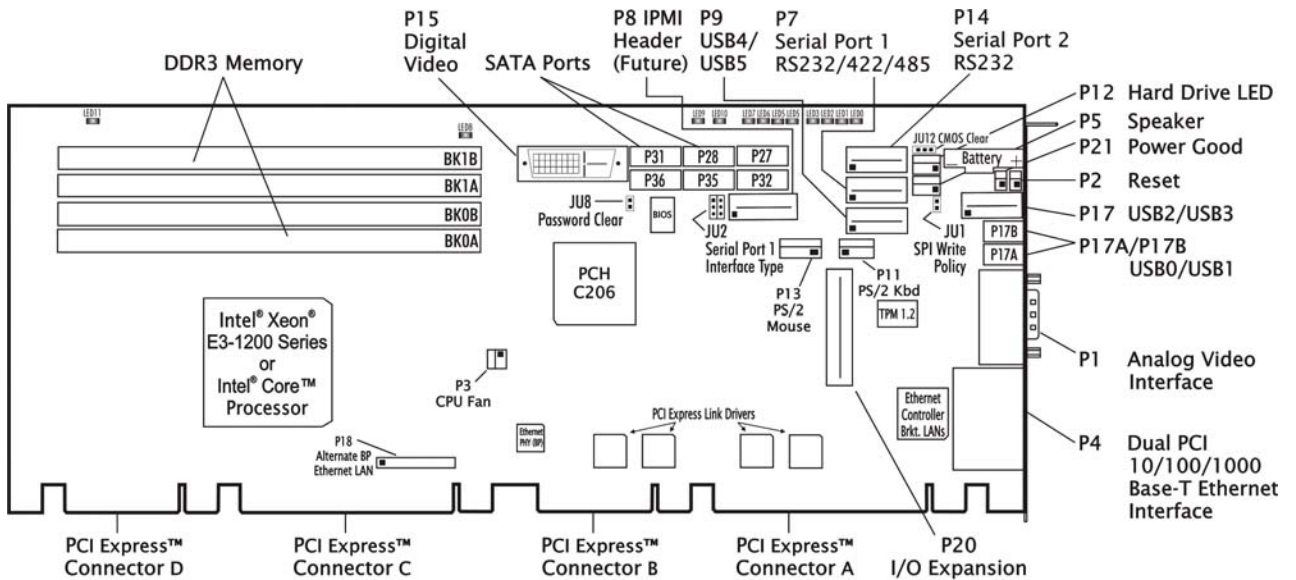

TRENTON Technology Inc.
2350 Centennial Drive • Gainesville, Georgia 30504
Sales (800) 875-6031 • Phone (770) 287-3100 • Fax (770) 287-3150

Technical Information – Compatible Backplanes, Jumpers, Connectors and Memory TSB7053 (7053-xxx) Single-Processor, PICMG 1.3 System Host Board

Layout Diagram, Revision -01 – Top



Layout Diagram, Revision -02 – Top

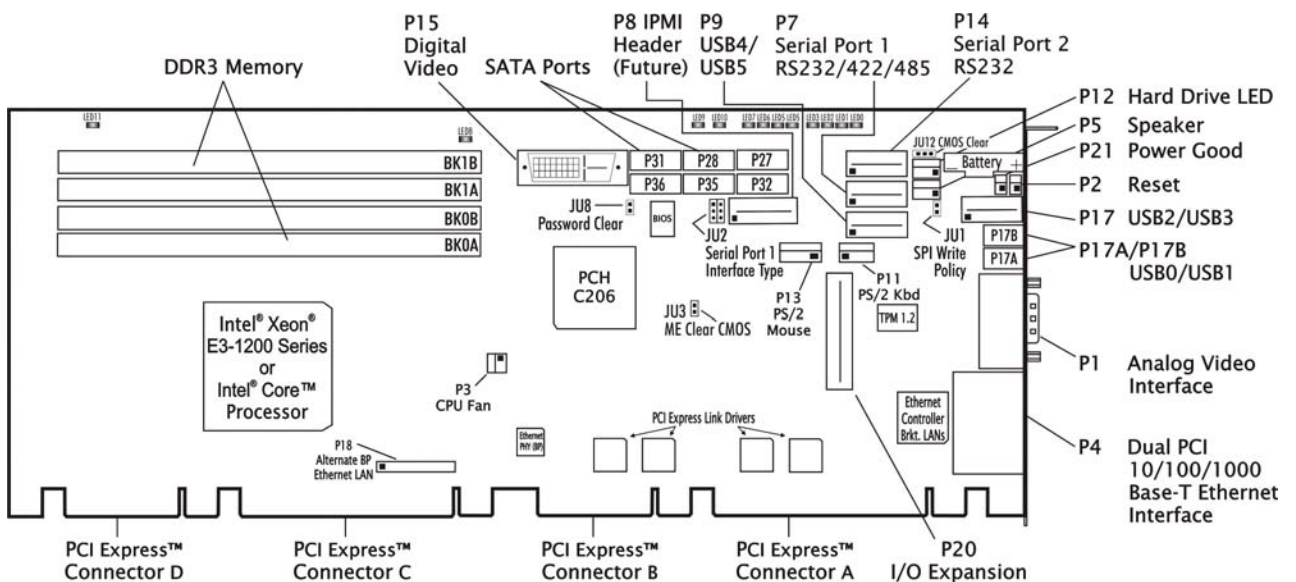



TRENTON Technology Inc.
 2350 Centennial Drive • Gainesville, Georgia 30504
 Sales (800) 875-6031 • Phone (770) 287-3100 • Fax (770) 287-3150

Layout Diagram, Revision -03 – Top

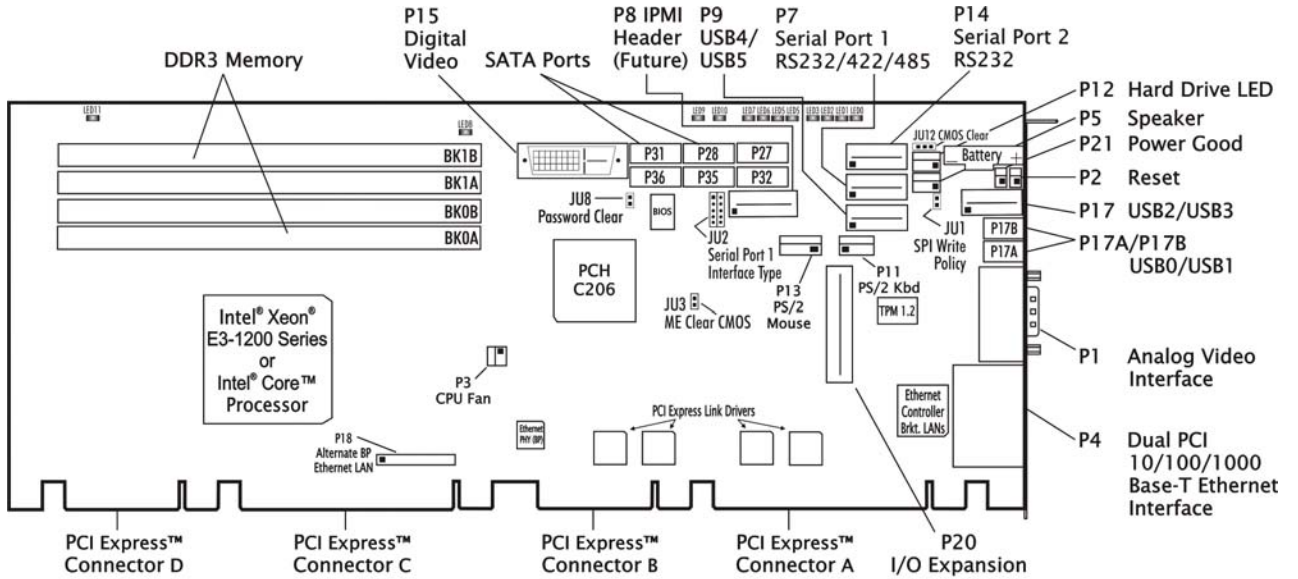

Layout Diagram – Bottom

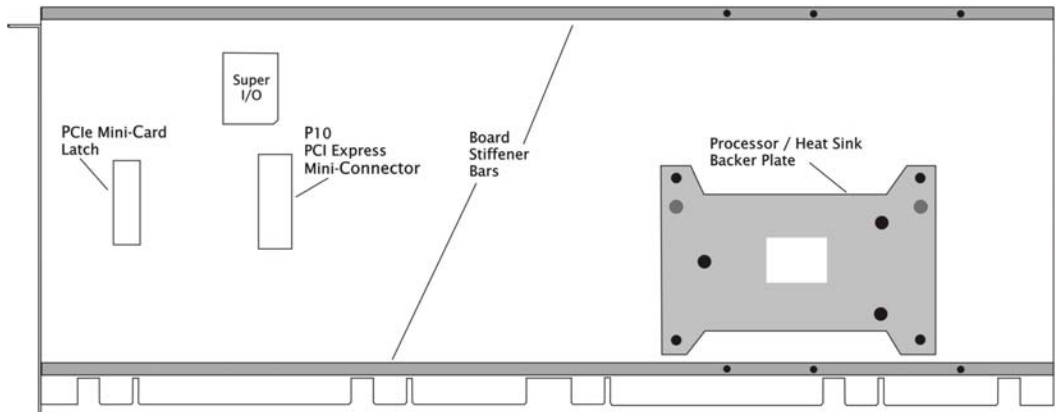



Jumpers & LEDs

The setup of the configuration jumpers on the SHB is described below. An asterisk (*) indicates the default value of each jumper.

NOTE: For the three-position JU12 jumper, "RIGHT" is toward the I/O bracket side of the board; "LEFT" is toward the header connector P14.

JU1 SPI Update (two position jumper)

Install for one power-up cycle to enable the board to unprotect the SHB's SPI storage device.
 Remove for normal operation. *

CAUTION: Installing this jumper is only done for special board operations such as changing the PCI Express link bifurcation operation. Contact Trenton tech support before installing this jumper to prevent any unintended system operation.

JU2 – Serial Port 1 Interface Configuration, Board Revisions -01 and -02

rev. -01 & -02 JU2 uses three jumpers to allow serial port one to be configured as either a RS232 or a RS422/RS485 electrical interface. The jumper tables below illustrate the possible interface configurations for serial port one.

JU2		
1	●	2
3	●	4
5	●	6

RS232 operation* – Jumper 1 to 2 and 3 to 4
 RS485 Full Duplex, No Termination – Jumper 1 to 2
 RS485 Half Duplex, No Termination – No jumpers installed
 RS485 Full Duplex, With Termination – Jumper 1 to 2 and 5 to 6
 RS485 Half Duplex, With Termination – Jumper 5 to 6

JU2 – Serial Port 1 Interface Configuration, Board Revision -03

rev. -03 In board revision -03 JU2 uses five jumpers to allow serial port one to be configured as either a RS232 or a RS422/RS485 electrical interface. The jumper tables below illustrate the possible interface configurations for serial port one.

JU2		
1	●	2
3	●	4
5	●	6
7	●	8
9	●	10

RS232 operation* – Jumper 1 to 2 and 3 to 4 and 9 to 10
 RS485 Full Duplex, No Termination – Jumper 1 to 2 and 9 to 10¹
 RS485 Half Duplex, No Termination – Jumper 9 to 10
 RS485 Full Duplex, With Termination – Jumper 1 to 2 and 5 to 6²
 RS485 Half Duplex, With Termination – Jumper 5 to 6 and 9 to 10

Notes:
 1 – Shut between pins 9 and 10 can optionally be removed to unconditionally enable the Tx driver
 2 – Shut between pins 9 and 10 can optionally be installed to unconditionally enable the Tx driver

JU3 – Clear Management Engine (ME) Operational Parameters (two position jumper), Board Rev -02 or later

rev. -02 or later The board's management engine has its own CMOS Non-Volatile Memory (NVM) that stores operational parameters for Intel AMT 7.0 implementations.

Install for one power-up cycle to clear management engine CMOS settings.
 Remove for normal operation. *

JU8 Password Clear (two position jumper)

Install for one power-up cycle to reset the password to the default (null password).
 Remove for normal operation. *



Jumpers & LEDs (continued)

JU12 CMOS Clear (three position jumper)

Install on the LEFT to clear.
 Install on the RIGHT to operate. *

NOTE: To clear the CMOS, power down the system and install the JU12 jumper on the LEFT. Wait for at least two seconds, move the jumper back to the RIGHT and turn the power on. Clearing CMOS on the TSB7053 will not result in a checksum error on the following boot. If you want to change a BIOS setting, you must press DEL or the F2 key during POST to enter BIOS setup after clearing CMOS.

P4A/P4B Ethernet LEDs

The I/O bracket houses the two RJ-45 network connectors for Ethernet LAN1 and LAN2. Each LAN interface connector has two LEDs that indicate activity status and Ethernet connection speed. Listed below are the possible LED conditions and status indications for each LAN connector:

LED/Connector Description

Activity LED	Green LED indicates network activity. This is the upper LED on the LAN connector (i.e., toward the upper memory sockets).
Off	No current network transmit or receive activity
On (flashing)	Indicates network transmit or receive activity.
Speed LED	This multi-color LED identifies the connection speed of the SHB's P4A (LAN2) and P4B (LAN1) Ethernet interfaces. These are the lower LEDs on the dual LAN connector (i.e., toward the edge connectors).
Green	Indicates a valid link at 1000-Mb/s or 1Gb/s
Orange	Indicates a valid link at 100-Mb/s.
Off	Indicates a valid link at 10-Mb/s
RJ-45 Network Connectors	The RJ-45 network connector requires a Connectors category 5 (CAT5) unshielded twisted-pair (UTP) 2-pair cable for a 100-Mb/s network connection or a category 3 (CAT3) or higher UTP 2-pair cable for a 10-Mb/s network connection. A category 5e (CAT5e) or higher UTP 2-pair cable is recommended for a 1000-Mb/s (Gigabit) network connection.



Status LEDs

LED8 - Backplane LAN LED

LED8 is located just above the right side of memory DIMM connector BK1B. A flashing LED8 indicates that network transmit and receive activity is occurring on the Ethernet LAN routed to the board's edge connector C / cable connector P18. This LAN provides a network interface for use on a compatible PICMG 1.3 backplane or over a cable.

LED9 - Thermal Trip LED

The thermal trip LED indicates when a processor reaches a shut down state. The LED is located just above the SATA connector P28. LED9 indicates the processor shutdown status and thermal conditions as illustrated below:

LED Status	Description
Off	Indicates the processor or processors are operating within acceptable thermal levels.
On (flashing)	Indicates a CPU is throttling down to a lower operating speed due to rising CPU temperature.
On (solid orange)	Indicates the CPU has reached the thermal shutdown threshold limit. The SHB may or may not be operating, but a board shutdown condition will soon occur.

NOTE: When a thermal shutdown occurs, the LED will stay on in systems using non- ATX/EPS power supplies. The CPU will cease functioning, but power will still be applied to the SHB. In systems with ATX/EPS power supplies, the LED will turn off when a thermal shutdown occurs because system power is removed via the ACPI soft control power signal S5. In this case, all SHB LEDs will turn off; however, stand-by power will still be present.

LED 10 - PCIe Mini Card WLAN LED

When LED10, located just to the right of LED9, is flashing this indicates that network transmit and receive activity is occurring on an Ethernet LAN that is located on an optional PCIe Mini Card connected to the TSB7053's Mini PCIe Expansion connector P10. P10 is located on the bottom side of the SHB.

LED11 - VRM LED

LED11 is a red LED located just above the left side of memory DIMM connector BK1B. If LED11 were to turn on and remain on, this would indicate that the voltage levels of the SHB's VRM circuits are not within the acceptable operating range. In all likelihood the SHB will fail to function if LED11 is on and the source of the voltage error could reside in the system power supply, the power supply wiring or on the board itself. Contact your system integrator or Trenton Tech Support for trouble shooting assistance.



POST Code LEDs 0 - 7

As the POST (Power On Self Test) routines are performed during boot-up, test codes are displayed on Port 80 POST Code LEDs 0, 1, 2, 3, 4, 5, 6 and 7. These LEDs are located on the top of the SHB, just above the board's SATA connectors and slightly toward the right. The POST Code LEDs are numbered from right (position 1 = LED0) to left (position 8 = LED7). Refer to the board layout diagram for the exact location of the POST code LEDs.

These POST codes may be helpful as a diagnostic tool. Specific test codes are listed in Appendix A - BIOS Messages section of the TSB7053 Technical Reference Manual. After a normal POST sequence the LEDs are off (00h) indicating that the SHB's BIOS has passed control over to the operating system loader typically at interrupt INT19h. The chart is from Appendix A and can be used to interpret the LEDs into hexadecimal format during POST.

Upper Nibble (UN)				
Hex. Value	LED7	LED6	LED5	LED4
0	Off	Off	Off	Off
1	Off	Off	Off	On
2	Off	Off	On	Off
3	Off	Off	On	On
4	Off	On	Off	Off
5	Off	On	Off	On
6	Off	On	On	Off
7	Off	On	On	On
8	On	Off	Off	Off
9	On	Off	Off	On
A	On	Off	On	Off
B	On	Off	On	On
C	On	On	Off	Off
D	On	On	Off	On
E	On	On	On	Off
F	On	On	On	On

Lower Nibble (LN)				
Hex. Value	LED3	LED2	LED1	LED0
0	Off	Off	Off	Off
1	Off	Off	Off	On
2	Off	Off	On	Off
3	Off	Off	On	On
4	Off	On	Off	Off
5	Off	On	Off	On
6	Off	On	On	Off
7	Off	On	On	On
8	On	Off	Off	Off
9	On	Off	Off	On
A	On	Off	On	Off
B	On	Off	On	On
C	On	On	Off	Off
D	On	On	Off	On
E	On	On	On	Off
F	On	On	On	On

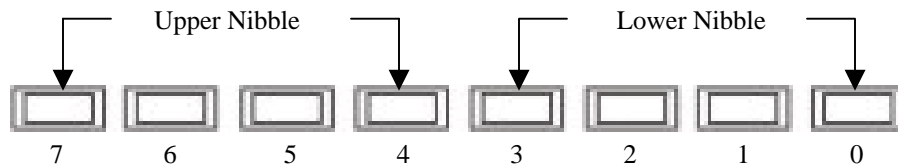

TSB7053 POST Code LEDs



Connectors

NOTE:

A connectors square solder pad located on the bottom side of the PCB indicates pin 1.

P1 – Analog Video Connector

15-socket analog video connector,
 Amp/TYCO 1-1734530-3:

PIN	SIGNAL	PIN	SIGNAL
1	Red	9	+5V
2	Green	10	Gnd
3	Blue	11	NC
4	NC	12	EEDI
5	Gnd	13	HSYNC
6	Gnd	14	VSYNC
7	Gnd	15	EECS
8	Gnd		

Note: Video connector supports standard analog video cables

P2 - Reset Connector

2 pin single row header, Amp #640456-2

PIN	SIGNAL
1	Gnd
2	Reset In

P3 – CPU Fan Power Connector

3 pin single row header, Molex #22-23-2031

PIN	SIGNAL
1	Gnd
2	+12V
3	Fan Tach

Note: P2 is the fan connector for CPU2 and P19 is for CPU1

P11 – PS/2 Keyboard Header

5 pin single row header, Amp #640456-5

PIN	SIGNAL
1	Kbd Clock
2	Kbd Data
3	NC
4	Kbd Gnd
5	Kbd Power (+5V fused) with self resetting fuse

P12 – Hard Drive LED Connector

4 pin single row header, Amp #640456-4

PIN	SIGNAL
1	LED +
2	LED -
3	LED -
4	LED +

P13 – PS/2 Mouse Header

6 pin single row header, Amp #640456-6

PIN	SIGNAL
1	Ms Data
2	NC
3	Gnd
4	Ms Power (+5V fused) with self resetting fuse
5	Ms Clock
6	NC

P21 – Power Good LED

2 pin single row header, Amp #640456-2

PIN	SIGNAL
1	LED -
2	LED +



Connectors (continued)

P4A/P4B – Dual 10/100/1000Base-T Ethernet Connector - LAN1 and LAN2

RJ-45/Dual connector, Pulse #JG0-0024NL

Each individual RJ-45 connector is defined as follows:

PIN	SIGNAL	PIN	SIGNAL
1A	L2_MDI0n	1B	L1_MDI0n
2A	L2_MDI0p	2B	L1_MDI0p
3A	L2_MDI1n	3B	L1_MDI1n
4A	L2_MDI1p	4B	L1_MDI1p
5A	L2_MDI2n	5B	L1_MDI2n
6A	L2_MDI2p	6B	L1_MDI2p
7A	L2_MDI3n	7B	L1_MDI3n
8A	L2_MDI3p	8B	L1_MDI3p
9A	VCC_1.8V	9B	VCC_1.8V
10A	GND_A	10B	GND_b

Notes:

- 1 – LAN ports support standard CAT5 Ethernet cables
- 2 – P4A is LAN2 and P4B is LAN1

P5 - Speaker Port Connector

4 pin single row header, Amp #640456-4

PIN	SIGNAL
1	Speaker Data
2	NC
3	Gnd
4	+5V

P7 – Serial Port 1 Connector – RS232 Connections

10 pin dual row header, Amp #5103308-1

PIN	SIGNAL	PIN	SIGNAL
1	Carrier Detect	2	Data Set Ready-I
3	Receive Data-I	4	Request to Send-O
5	Transmit Data-O	6	Clear to Send
7	Data Terminal Ready-O	8	Ring Indicator-I
9	Gnd	10	NC

Note: See JU2 pin-puts listed in the Jumpers & LEDs section on this document to enable serial port 1 signal connections.

P14 – Serial Port 2 Connector – RS232 Connections

10 pin dual row header, Amp #5103308-1

PIN	SIGNAL	PIN	SIGNAL
1	Carrier Detect	2	Data Set Ready-I
3	Receive Data-I	4	Request to Send-O
5	Transmit Data-O	6	Clear to Send
7	Data Terminal Ready-O	8	Ring Indicator-I
9	Gnd	10	NC

P15 – Digital Video Connector (DVI-D)

24-socket digital video connector, Molex #74320-5006

PIN	SIGNAL	PIN	SIGNAL	PIN	SIGNAL
1	DVI_TX2N	9	DVI_TX1N	17	DVI_TX0N
2	DVI_TX2P	10	DVI_TX1P	18	DVI_TX0P
3	Gnd	11	Gnd	19	Gnd
4	NC	12	NC	20	NC
5	NC	13	NC	21	NC
6	DVI_SCLK	14	5V	22	Gnd
7	DVI_SDAT	15	Gnd	23	DVI_TXCP
8	NC	16	DVI_HPD	24	DVI_TXCN

Note: Video connector supports standard DVI-D digital video cables

P17 – Dual Universal Serial Bus (USB) Connector

10 pin dual row header, Amp #1761610-3

(+5V fused with self-resetting fuse)

PIN	P17A SIGNAL	PIN	P17B SIGNAL
1	+5V-USB2	2	+5V-USB3
3	USB2-	4	USB3-
5	USB2+	6	USB3+
7	Gnd-USB2	8	Gnd-USB3
9	NC	10	NC

Note: P17 odd pins are for USB2 and the even pins are USB3



Connectors (continued)

P7 – Serial Port 1 Connector – RS422/RS485 Full Duplex Connections

10 pin dual row header, Amp #5103308-1

PIN	SIGNAL	PIN	SIGNAL
1	Not applicable	2	Not applicable
3	RX+	4	TX+
5	TX-	6	RX-
7	Not applicable	8	Not applicable
9	Gnd	10	NC

Note: See JU2 pin-puts listed in the Jumpers & LEDs section on this document to enable serial port 1 signal connections.

P7 – Serial Port 1 Connector – RS485 Half Duplex Connections

10 pin dual row header, Amp #5103308-1

PIN	SIGNAL	PIN	SIGNAL
1	Not applicable	2	Not applicable
3	Not applicable	4	DATA+
5	DATA-	6	Not applicable
7	Not applicable	8	Not applicable
9	Gnd	10	NC

Note: See JU2 pin-puts listed in the Jumpers & LEDs section on this document to enable serial port 1 signal connections.

P9 – Dual Universal Serial Bus (USB) Connector

10 pin dual row header, Amp #1761610-3
 (+5V fused with self-resetting fuse)

PIN	P17A SIGNAL	PIN	P17B SIGNAL
1	+5V-USB4	2	+5V-USB5
3	USB4-	4	USB5-
5	USB4+	6	USB5+
7	Gnd-USB4	8	Gnd-USB5
9	NC	10	NC

P17A, P17B – Universal Serial Bus (USB) Connectors (I/O Bracket)

USB vertical connectors, Molex #67329-8001
 (+5V fused with self-resetting fuse)

PIN	P17A SIGNAL	PIN	P17B SIGNAL
1	+5V-USB0	1	+5V-USB1
2	USB0-	2	USB1-
3	USB0+	3	USB1+
4	Gnd-USB0	4	Gnd-USB1

Note: P17A is USB0 and P17B is USB1

P18 - 10/100/1000Base-T Ethernet Connector – Alternate Backplane LAN Over Cable

8 pin single row connector, Molex #0554500859

PIN	SIGNAL
1	A_MDI2N
2	A_MDI2P
3	A_MDI3N
4	A_MDI3P
5	A_MDI1N
6	A_MDI1P
7	A_MDI0N
8	A_MDI0P

Note:

The mating Molex connector to use when making this alternative Ethernet cable has a Molex part number of 0513360810.

P27, P28, P31, P32, P35, P36 – SATA II 300 Ports

7 pin vertical locking connector, Molex #67800-8005

PIN	SIGNAL	PIN	SIGNAL
1	Gnd	5	RX-
2	TX+	6	RX+
3	TX-	7	Gnd
4	Gnd		

Notes:

- 1 – P27 = SATA0 interface, P28 = SATA1 interface, P31 = SATA2 interface, P32 = SATA3 interface, P35 = SATA4 interface, P36 = SATA5 interface,
- 2 – SATA connectors support standard SATA interface cables
- 3 – P27 & P28 (SATA0 and SATA1 ports) support SATA 3.0, SATA 2.0 and SATA 1.0 devices while all other SATA ports support SATA 2.0 and SATA 1.0 devices
- 4 – SATA 3.0 = 600MB/s data transfers, SATA 2.0 = 300MB/s data transfers and SATA 1.0 = 150MB/s data transfers



Connectors (continued)

P10 – PCI Express Mini Card Connector (SHB bottom side)

Standard 52-pin PCIe mini-card edge connector

PIN	SIGNAL	PIN	SIGNAL
1	PCH_WAKE#	2	VCC3_MINIPCI
3	NC	4	GND
5	NC	6	VCC1_5_MINIPE
7	VCC3_MINIPCI	8	NC
9	GND	10	NC
11	MINIPCI_CLK100N	12	NC
13	MINIPCI_CLK100P	14	NC
15	GND	16	NC
17	NC	18	GND
19	NC	20	NC
21	GND	22	EXP_RESET#
23	MINI_PE_RXN0	24	3.3V AUX
25	MINI_PE_RXP0	26	GND
27	GND	28	VCC1_5_MINIPE
29	GND	30	SMBCLK_RESUME
31	MINI_PE_TXN0	32	SMBDAT_RESUME
33	MINI_PE_TXP0	34	GND
35	GND	36	USBP6-
37	NC	38	USBP6+
39	NC	40	GND
41	NC	42	NC
43	NC	44	WLAN_LED10
45	CLINK_CLK	46	NC
47	CLINK_DAT	48	VCC1_5_MINIPE
49	CLINK_RST#	50	GND
51	NC	52	VCC3_MINIPCI

P20 - I/O Expansion Mezzanine Card Connector (For IOBxx option modules)

76 pin controlled impedance connector, Samtec #MIS-038-01-FD-K

PIN	SIGNAL	PIN	SIGNAL
1	+12V	2	+5V_STANDBY
3	HDA_SDIN2	4	+5V_STANDBY
5	HDA_SDIN1	6	+5V_DUAL
7	HDA_SDIN0	8	+5V_DUAL
9	HDA_SYNC	10	HDA_BITCLK
11	HDA_SDOUT	12	HDA_ACRST
13	ICH_SMI#	14	ICH_RCIN#
15	ICH_SIOPME#	16	ICH_A20GATE
17	Gnd	18	Gnd
19	L_FRAME#	20	L_AD3
21	L_DRQ1#	22	L_AD2
23	L_DRQ0#	24	L_AD1
25	SERIRQ	26	L_AD0
27	Gnd	28	Gnd
29	PCLK14SIO	30	PCLK33LPC
31	Gnd	32	Gnd
33	SMBDATA_RESUME	34	IPMB_DAT
35	SMBCLK_RESUME	36	IPMB_CLK
37	SALRT#_RESUME	38	IPMB_ALRT#
39	Gnd	40	Gnd
41	EXP_CLK100	42	EXP_RESET#
43	EXP_CLK100#	44	ICH_WAKE#
45	Gnd	46	Gnd
47	C_PE_TXP5	48	C_PE_RXP5
49	C_PE_TXN5	50	C_PE_RXN5
51	Gnd	52	Gnd
53	NC	54	NC
55	NC	56	NC
57	Gnd	58	Gnd
59	NC	60	NC
61	NC	62	NC
63	Gnd	64	Gnd
65	NC	66	NC
67	NC	68	NC
69	Gnd	70	Gnd
71	+3.3V	72	+5V
73	+3.3V	74	+5V
75	+3.3V	76	+5V



Memory

The processor on the TSB7053 supports two, dual-channel DDR3-1333 memory interfaces. There are four DDR3 DIMM sockets on the board. Total system memory capacity is 32GB when using standard 8GB DDR3 DIMMs and 16GB when using 4GB DIMMs. The peak memory interface bandwidth is 32GB/s per memory channel with a peak DDR3 data transfer rate of 1333 MT/s when using PC3-10600 (i.e. DDR3-1333) DIMMs. A typical memory interface bandwidth average is 17GB/s, but your actual memory interface bandwidth results will vary as a function of CPU and memory type as well as the number of memory DIMMs installed. Populating the DIMM sockets in memory channel pairs will result in better memory bandwidth and faster data transfers. The system BIOS automatically detects memory type, size and speed.

Trenton recommends unbuffered ECC PC3-8500 or PC3-10600 DDR3 memory modules for use on the TSB7053. These unbuffered ECC registered (64-bit) DDR3 DIMMs must be PC3-10600 or PC3-8500 compliant. Unbuffered non-ECC DDR3 DIMMs are also supported on the TSB7053 SHB, but you cannot mix the two different memory types on the same board.

The SHB uses industry standard gold finger standard DIMM memory modules, which must be PC3-10600 or PC3-8500 compliant and have the following features:

- Gold-plated contacts
- ECC registered (64-bit) DDR3 memory
- 240-pin

The following DIMM sizes are supported:

MT/s	DIMM Type	Rank	DRAM Component Density	DIMM Module Capacities
1333	PC3-10600	Single or Dual	1GB, 2GB, 4GB	1GB, 2GB, 4GB, 8GB
1066	PC3-8500	Single or Dual	1GB, 2GB, 4GB	1GB, 2GB, 4GB, 8GB

NOTE 1: To maximize memory interface speed, populate each memory channel with DDR3 DIMMs having the same interface speed. The SHB will support DIMMs with different speeds, but the memory channel interface will operate speed of the slowest DIMM.

NOTE 2: The SHB supports the following memory module memory latency timings:

- 7-7-7 and 8-8-8 for 1066MHz DDR3 DIMMs
- 9-9-9 for 1333MHz DDR3 DIMMs

NOTE 3: Populate the memory sockets starting with memory channel A and begin by using the DIMM socket closest to the CPU first. Refer to the TSB7053 board layout drawing and populate the memory sockets using the population order illustrated in the chart below:

Population order	CPU1
1	BK0A
2	BK1A
3	BK0B
4	BK1B

[TSB7053 Product Detail](#)