

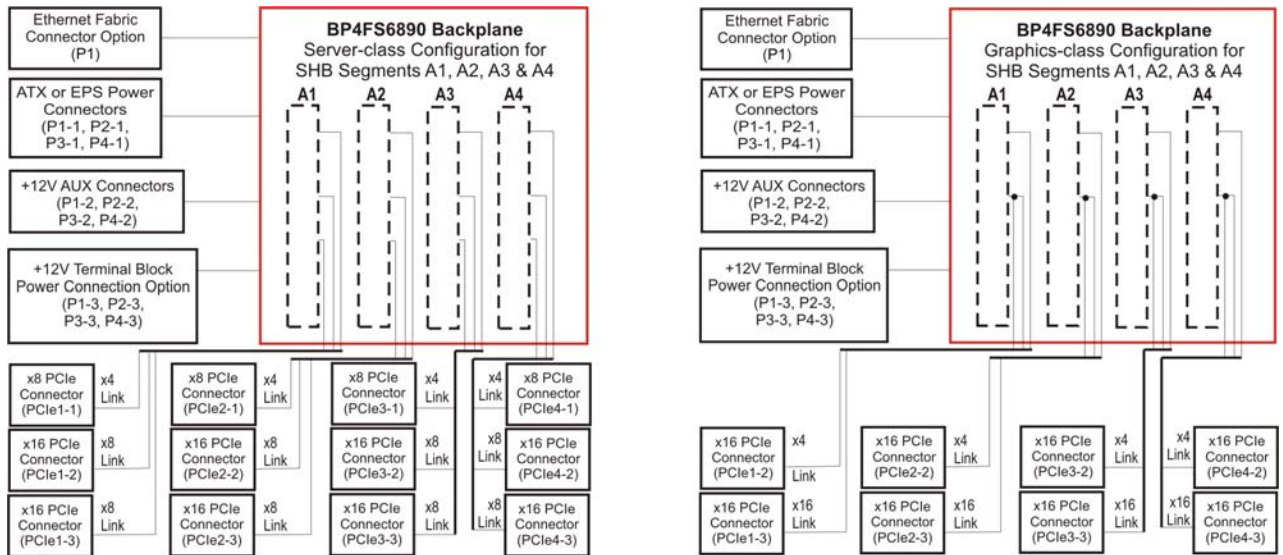

TRENTON Technology Inc.
 2350 Centennial Drive • Gainesville, Georgia 30504
 Sales (800) 875-6031 • Phone (770) 287-3100 • Fax (770) 287-3150

Technical Information – Jumpers and Connectors BP4FS6890 (6890) Four-Segment PCI Express Backplane

Block Diagrams



Layout Diagram – 6890 Server-Class Configuration

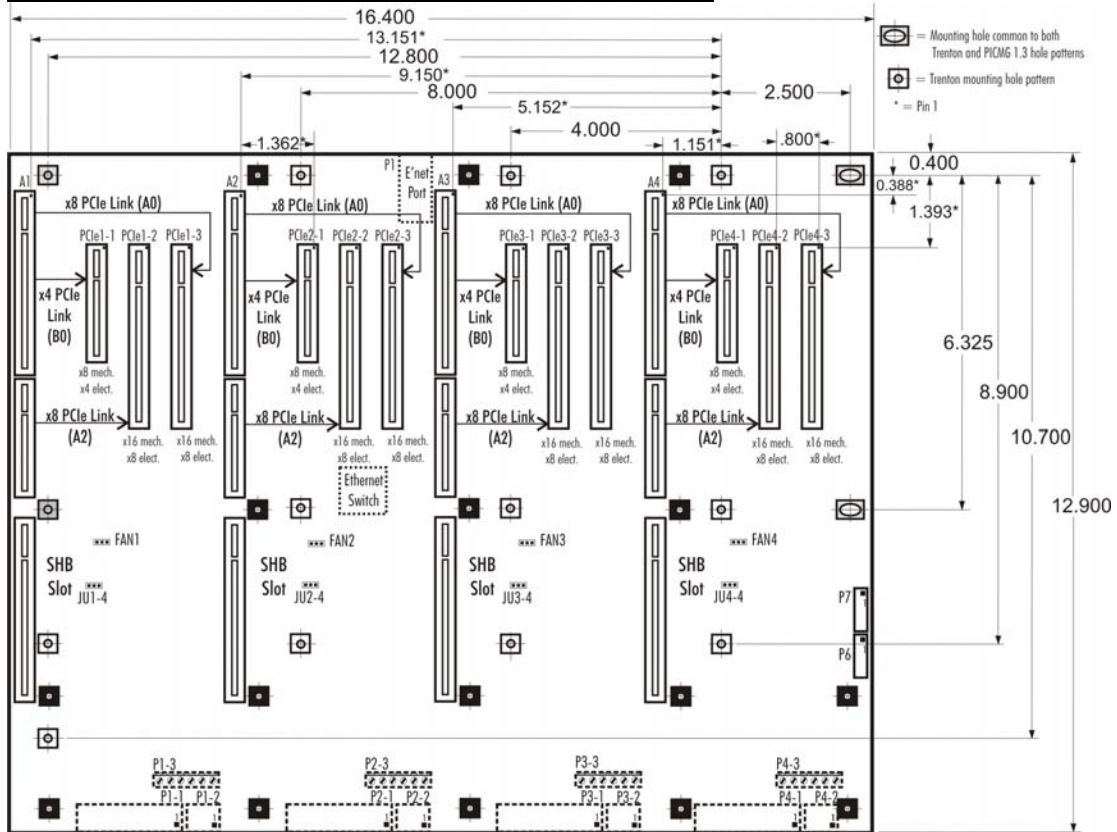



TRENTON Technology Inc.
2350 Centennial Drive • Gainesville, Georgia 30504
Sales (800) 875-6031 • Phone (770) 287-3100 • Fax (770) 287-3150

Layout Diagram – 6890 Graphics-Class Configuration

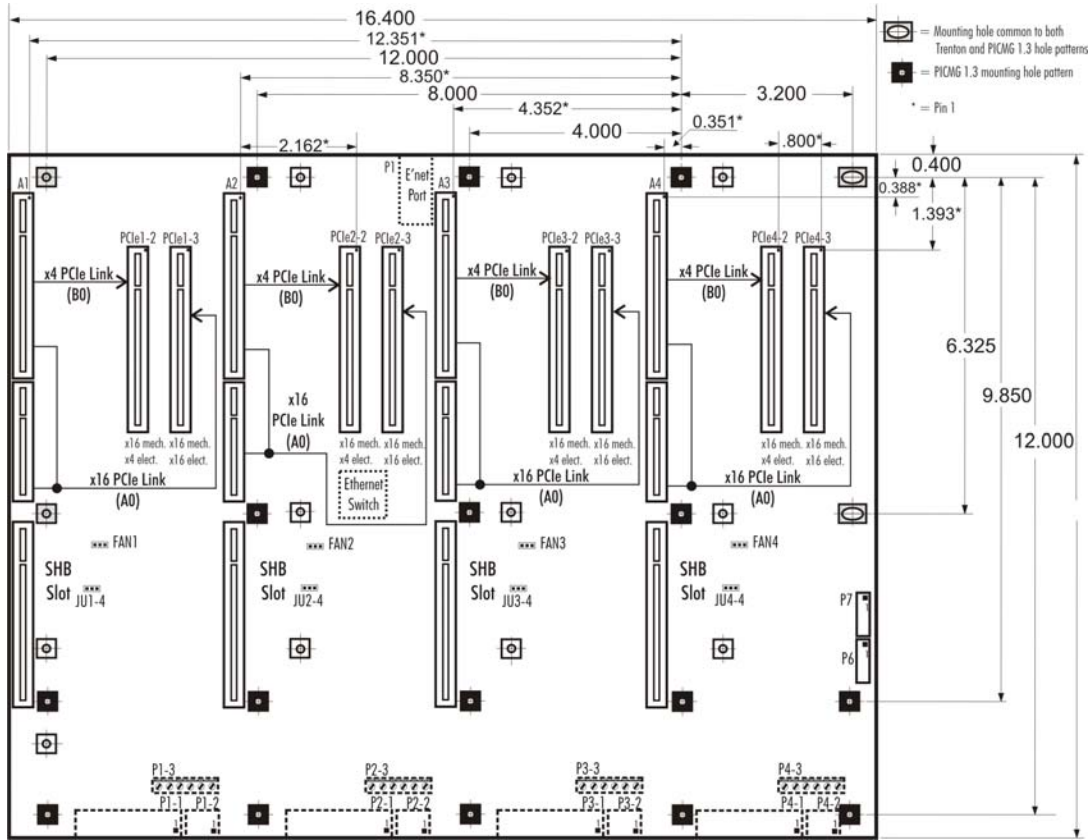

Notes:

- Dotted lines indicate connectors and other components that are populated based on model name and number.
- Typical PCIe connector centers are 0.049" from pin 1
- Mounting holes have a nominal 0.156" diameter
- Nominal PCB thickness: 0.080"
- All dimensions are inches.
- Suggested Trenton server-class PICMG 1.3 SHBs for use with the server-class BP4FS6890 backplane models:
 - Dual-processor SHBs: MCXT, MCXT-E, SLT and NLT
 - Single-processor SHBs: MCXI, SLI and NLI
- Suggested Trenton graphics-class PICMG 1.3 SHBs for use with graphics-class BP4FS6890 backplane models:
 - Dual-processor SHBs: MCGT and MCGT-E
 - Single-processor SHBs: MCGI, TQ9, TML and T4L
- Trenton SLT, SLI, NLT and NLI system host boards do not support the Ethernet option on the BP4FS6890 backplane



BP4FS6890 Backplane Configuration Table

The BP4FS6890 four-segment PICMG 1.3 backplane can be factory-configured to operate with either PICMG 1.3 Graphics- or Server-class system host boards (SHBs). The model number column in the table below indicates the backplane's specific configuration. Server-class configurations must be matched to server-class SHBs and graphics-class configurations must be matched with graphics-class SHBs for optimum system performance.

| Model# | Model Name & Type | SHB Connector D | ATX/EPS Connectors P1-1 P2-1 P3-1 P4-1 | +12V Aux Connectors P1-2 P2-2 P3-2 P4-2 | +12V Terminal Blocks P1-3 P2-3 P3-3 P4-3 | Ethernet Hub and Port P1 | PCIe slots per SHB segment |
|---------------|---|------------------------|---|--|---|---------------------------------|---|
| 6890-005 | BP4FS6890-SCSR, Server-class, Standalone, Right-angle ATX/EPS power connectors | No | Yes | Yes | No | No | 2 – x16 mech. / x8 elect. 1 – x8 mech. / x4 elect. |
| 6890-016 | BP4FS6890-SCST, Server-class, Standalone, Terminal Block connectors | No | No | No | Yes | No | 2 – x16 mech. / x8 elect. 1 – x8 mech. / x4 elect. |
| 6890-025 | BP4FS6890-SCER, Server-class, Ethernet, Right-angle ATX/EPS power connectors | No | Yes | Yes | No | Yes* | 2 – x16 mech. / x8 elect. 1 – x8 mech. / x4 elect. |
| 6890-036 | BP4FS6890-SCET, Server-class, Ethernet, Terminal Block connectors | No | No | No | Yes | Yes* | 2 – x16 mech. / x8 elect. 1 – x8 mech. / x4 elect. |
| 6890-105 | BP4FS6890-GC1SR, Graphics-class, Standalone, Right-angle ATX/EPS power connectors | No | Yes | Yes | No | No | 2 – x16 mech. -- 1 x16 elect. & 1 x4 elect. |
| 6890-116 | BP4FS6890-GC1ST, Graphics-class, Standalone, Terminal Block connectors | No | No | No | Yes | No | 2 – x16 mech. -- 1 x16 elect. & 1 x4 elect. |
| 6890-125 | BP4FS6890-GC1ER, Graphics-class, Ethernet, Right-angle ATX/EPS power connectors | No | Yes | Yes | No | Yes | 2 – x16 mech. -- 1 x16 elect. & 1 x4 elect. |
| 6890-136 | BP4FS6890-GC1ET, Graphics-class, Ethernet, Terminal Block connectors | No | No | No | Yes | Yes | 2 – x16 mech. -- 1 x16 elect. & 1 x4 elect. |

*Trenton SLT/SLI and NLT/NLI system host boards do not support the Ethernet function on the backplane



TRENTON Technology Inc.
2350 Centennial Drive • Gainesville, Georgia 30504
Sales (800) 875-6031 • Phone (770) 287-3100 • Fax (770) 287-3150

BP4FS6890 (6890) Configuration Jumpers

The setup of each SHB segment's configuration jumper on the backplane is described below. * indicates the default value of the jumper.

NOTE: For the two-position jumper (3-post) in SHB segments, "RIGHT" and "LEFT" refer to positioning when the backplane is viewed with the SHB's I/O plate(s) at the top end of the backplane.

NOTE: JU4, 1-2 indicates the JU4 jumper in SHB segments one and two while JU4, 3-6 means the JU4 jumper in SHB segment three, four, five and six.

| <u>Jumper</u> | <u>Description</u> |
|---------------------------------------|--|
| JU1-4, JU2-4, JU3-4, JU4-4 | +5V Auxiliary Voltage Install on the LEFT if +5V auxiliary voltage is provided by the standard +5V supply. This option is used for systems which do not have either an ATX or EPS standard power input. This mode provides the necessary +5V for the SHB's +5VAUX signal lines. Sleep mode recovery is not supported using non-ATX/EPS power supplies. * Install on the RIGHT if +5V auxiliary voltage is provided by a separate +5VAUX signal input pin. This enables the necessary SHB power signaling and allows recovery from sleep mode. This option is used for ATX or EPS standard power supplies. |



BP4FS6890 (6890) Connectors

NOTE: Pin 1 on the connectors is indicated by the square pad on the PCB.

P1-1, P2-1 **EPS Power Connector**
P3-1, P4-1 24 pin vertical dual row, Molex #44206-0007

| <u>Pin</u> | <u>Signal</u> | <u>Pin</u> | <u>Signal</u> |
|------------|---------------|------------|---------------|
| 1 | +3.3V | 13 | +3.3V |
| 2 | +3.3V | 14 | -12V |
| 3 | Gnd | 15 | Gnd |
| 4 | +5V | 16 | PSO# |
| 5 | Gnd | 17 | Gnd |
| 6 | +5V | 18 | Gnd |
| 7 | Gnd | 19 | Gnd |
| 8 | PWRGD | 20 | -5V |
| 9 | +5VAUX | 21 | +5V |
| 10 | +12V | 22 | +5V |
| 11 | +12V | 23 | +5V |
| 12 | +3.3V | 24 | Gnd |

P1-2, P2-2 **+12V Power Connector**
P3-2, P4-2 8 pin vertical dual row, Molex #44206-0005

| <u>Pin</u> | <u>Signal</u> | <u>Pin</u> | <u>Signal</u> |
|------------|---------------|------------|---------------|
| 1 | Gnd | 5 | +12V |
| 2 | Gnd | 6 | +12V |
| 3 | Gnd | 7 | +12V |
| 4 | Gnd | 8 | +12V |

P1-3, P2-3 **Terminal Block Connector**
P3-3, P4-3 6 position terminal block, AMP, #796949-4
20 Amps per circuit

| <u>Pin</u> | <u>Signal</u> |
|------------|---------------|
| 1 | +12V |
| 2 | +12V |
| 3 | +12V |
| 4 | Gnd |
| 5 | Gnd |
| 6 | Gnd |

P6 **PSO# and SHB Reset Signal Connector**
16 pin dual row connector, 3M, #N2516-6002RB

| <u>Pin</u> | <u>Signal</u> | <u>Pin</u> | <u>Signal</u> |
|------------|---------------|------------|---------------|
| 1 | PSO# - 1 | 2 | Gnd - 1 |
| 3 | PSO# - 2 | 4 | Gnd - 2 |
| 5 | PSO# - 3 | 6 | Gnd - 3 |
| 7 | PSO# - 4 | 8 | Gnd - 4 |
| 9 | SHB_RST - 1 | 10 | Gnd - 1 |
| 11 | SHB_RST - 2 | 12 | Gnd - 2 |
| 13 | SHB_RST - 3 | 14 | Gnd - 3 |
| 15 | SHB_RST - 4 | 16 | Gnd - 4 |



BP4FS6890 (6890) Connectors (continued)

P7 Power Button and Power Good Signal Connector

16 pin dual row connector, 3M, #N2516-6002RB

| <u>Pin</u> | <u>Signal</u> | <u>Pin</u> | <u>Signal</u> |
|------------|---------------|------------|---------------|
| 1 | PWRBT# - 1 | 2 | Gnd - 1 |
| 3 | PWRBT# - 2 | 4 | Gnd - 2 |
| 5 | PWRBT# - 3 | 6 | Gnd - 3 |
| 7 | PWRBT# - 4 | 8 | Gnd - 4 |
| 9 | PWRGD - 1 | 10 | Gnd - 1 |
| 11 | PWRGD - 2 | 12 | Gnd - 2 |
| 13 | PWRGD - 3 | 14 | Gnd - 3 |
| 15 | PWRGD - 4 | 16 | Gnd - 4 |

P1 10/100/1000 Base-T Ethernet Connector – Backplane Hub Port (OPTIONAL)

8 pin right angle shielded RJ-45 connector, Pulse, #J0035D21BNL

| <u>Pin</u> | <u>Signal</u> |
|------------|---------------|
| 1 | RXD- |
| 2 | RXD+ |
| 3 | RCI |
| 4 | RC |
| 5 | TC |
| 6 | TCI |
| 7 | TXD- |
| 8 | TXD+ |

FAN1 Available System Cooling Fan Power Connector

FAN2 Standard 3 pin cooling fan power header

FAN3

FAN4

| <u>Pin</u> | <u>Signal</u> |
|------------|---------------|
| 1 | Gnd |
| 2 | +12V |
| 3 | NC |