

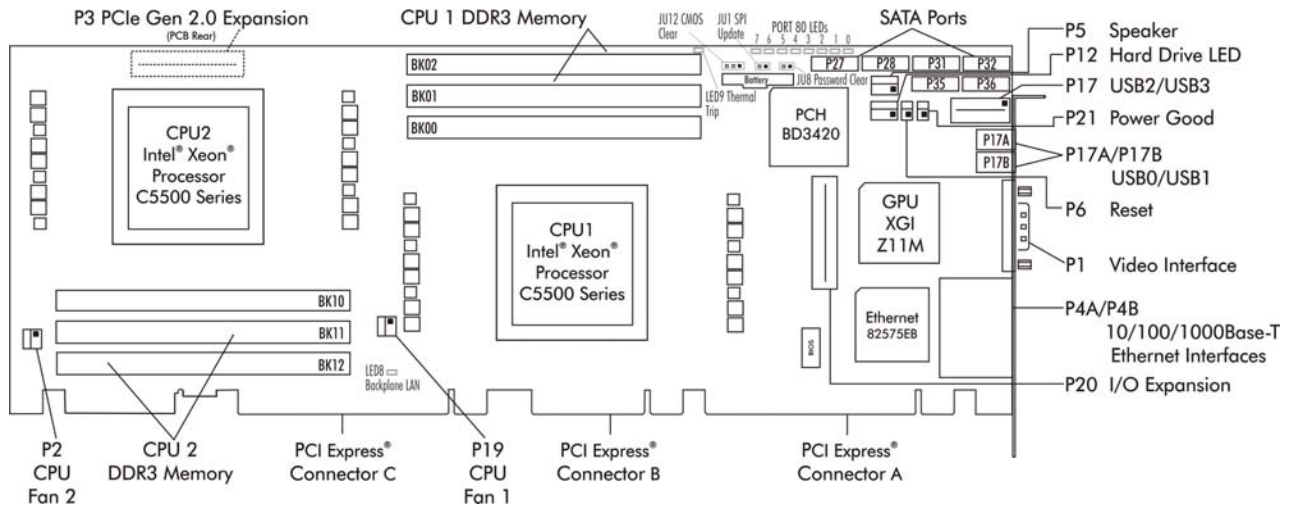

Technical Information – Compatible Backplanes, Jumpers, Connectors and Memory JXT6966 (6966-xxx) Dual-Processor, PICMG 1.3 System Host Board

Layout Diagram



Jumpers & LEDs

The setup of the configuration jumpers on the SHB is described below. An asterisk (*) indicates the default value of each jumper.

NOTE: For the three-position JU12 jumper, "RIGHT" is toward the I/O bracket side of the board; "LEFT" is toward the CPU1 DDR3 Memory sockets.

JU1 SPI Update (two position jumper)

Install for one power-up cycle to enable the board to unprotect the SHB's SPI storage device.
Remove for normal operation. *

CAUTION: Installing this jumper is only done for special board operations such as changing the PCI Express link bifurcation operation. Contact Trenton tech support *before* installing this jumper to prevent any unintended system operation.

JU8 Password Clear (two position jumper)

Install for one power-up cycle to reset the password to the default (null password).
Remove for normal operation. *

JU12 CMOS Clear (three position jumper)

Install on the LEFT to clear.
Install on the RIGHT to operate. *

NOTE: To clear the CMOS, power down the system and install the JU12 jumper on the LEFT. Wait for at least two seconds, move the jumper back to the RIGHT and turn the power on. Clearing CMOS on the JXT6966 will not result in a checksum error on the following boot. If you want to change a BIOS setting, you must press DEL or the F2 key during POST to enter BIOS setup after clearing CMOS.



Jumpers & LEDs (continued)

P4A/P4B Ethernet LEDs

The I/O bracket houses the two RJ-45 network connectors for Ethernet LAN1 and LAN2. Each LAN interface connector has two LEDs that indicate activity status and Ethernet connection speed. Listed below are the possible LED conditions and status indications for each LAN connector:

LED/Connector	Description
Activity LED	Green LED indicates network activity. This is the upper LED on the LAN connector (i.e., toward the upper memory sockets).
Off	No current network transmit or receive activity
On (flashing)	Indicates network transmit or receive activity.
Speed LED	Green LED which identifies the connection speed. This is the lower LED on the LAN connector (i.e., toward the edge connectors).
Off	Indicates a valid link at 1000-Mb/s
On	Indicates a valid link at 100-Mb/s.
RJ-45 Network Connectors	The RJ-45 network connector requires a Connectors category 5 (CAT5) unshielded twisted-pair (UTP) 2-pair cable for a 100-Mb/s network connection or a category 3 (CAT3) or higher UTP 2-pair cable for a 10-Mb/s network connection. A category 5e (CAT5e) or higher UTP 2-pair cable is recommended for a 1000-Mb/s (Gigabit) network connection.

LED9 - Thermal Trip LED

The thermal trip LED indicates when a processor reaches a shut down state. The LED is located just above the BK02 DIMM socket. LED9 indicates the processor shutdown status and thermal conditions as illustrated below:

LED Status	Description
Off	Indicates the processor or processors are operating within acceptable thermal levels.
On (flashing)	Indicates a CPU is throttling down to a lower operating speed due to rising CPU temperature.
On (solid orange)	Indicates the CPU has reached the thermal shutdown threshold limit. The SHB may or may not be operating, but a board shutdown condition will soon occur.

NOTE: When a thermal shutdown occurs, the LED will stay on in systems using non- ATX/EPS power supplies. The CPU will cease functioning, but power will still be applied to the SHB. In systems with ATX/EPS power supplies, the LED will turn off when a thermal shutdown occurs because system power is removed via the ACPI soft control power signal S5. In this case, all SHB LEDs will turn off; however, stand-by power will still be present.



POST Code LEDs 0 - 7

As the POST (Power On Self Test) routines are performed during boot-up, test codes are displayed on Port 80 POST Code LEDs 0, 1, 2, 3, 4, 5, 6 and 7. These LED are located on the top of the SHB, just above the board's battery socket. The POST Code LEDs are numbered from right (position 1 = LED0) to left (position 8 – LED7). Refer to the board layout diagram for the exact location of the POST code LEDs.

These POST codes may be helpful as a diagnostic tool. Specific test codes are listed in Appendix A - BIOS Messages section of the JXT6966 Technical Reference Manual. After a normal POST sequence the LEDs are off (00h) indicating that the SHB's BIOS has passed control over to the operating system loader typically at interrupt INT19h. The chart is from Appendix A and can be used to interpret the LEDs into hexadecimal format during POST.

Upper Nibble (UN)				
Hex. Value	LED7	LED6	LED5	LED4
0	Off	Off	Off	Off
1	Off	Off	Off	On
2	Off	Off	On	Off
3	Off	Off	On	On
4	Off	On	Off	Off
5	Off	On	Off	On
6	Off	On	On	Off
7	Off	On	On	On
8	On	Off	Off	Off
9	On	Off	Off	On
A	On	Off	On	Off
B	On	Off	On	On
C	On	On	Off	Off
D	On	On	Off	On
E	On	On	On	Off
F	On	On	On	On

Lower Nibble (LN)				
Hex. Value	LED3	LED2	LED1	LED0
0	Off	Off	Off	Off
1	Off	Off	Off	On
2	Off	Off	On	Off
3	Off	Off	On	On
4	Off	On	Off	Off
5	Off	On	Off	On
6	Off	On	On	Off
7	Off	On	On	On
8	On	Off	Off	Off
9	On	Off	Off	On
A	On	Off	On	Off
B	On	Off	On	On
C	On	On	Off	Off
D	On	On	Off	On
E	On	On	On	Off
F	On	On	On	On

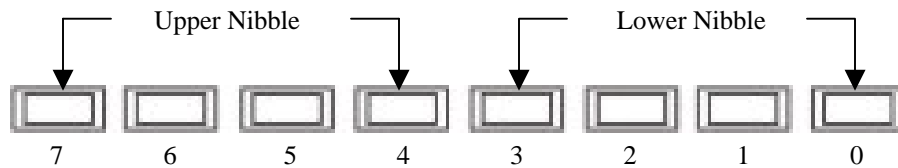

JXT6966 POST Code LEDs



Connectors

NOTE:

A connectors square solder pad located on the bottom side of the PCB indicates pin 1.

P4A/P4B – Dual 10/100/1000Base-T Ethernet Connector - LAN1 and LAN2

RJ-45/Dual connector, Pulse #JG0-0024NL

Each individual RJ-45 connector is defined as follows:

PIN	SIGNAL	PIN	SIGNAL
1A	L2_MDI0n	1B	L1_MDI0n
2A	L2_MDI0p	2B	L1_MDI0p
3A	L2_MDI1n	3B	L1_MDI1n
4A	L2_MDI1p	4B	L1_MDI1p
5A	L2_MDI2n	5B	L1_MDI2n
6A	L2_MDI2p	6B	L1_MDI2p
7A	L2_MDI3n	7B	L1_MDI3n
8A	L2_MDI3p	8B	L1_MDI3p
9A	VCC_1.8V	9B	VCC_1.8V
10A	GND_A	10B	GND_b

Notes:

- 1 – LAN ports support standard CAT5 Ethernet cables
- 2 – P4A is LAN2 and P4B is LAN1

P1 –Video Connector

15-pin Video connector, Kycon K31X-E15S-N:

PIN	SIGNAL	PIN	SIGNAL
1	Red	9	+5V
2	Green	10	Gnd
3	Blue	11	NC
4	NC	12	EEDI
5	Gnd	13	HSYNC
6	Gnd	14	VSYNC
7	Gnd	15	EECS
8	Gnd		

Note:

- 1 – Video connector supports standard DB15 video cables

P17 – Dual Universal Serial Bus (USB) Connector

10 pin dual row header, Molex #702-46-1001
 (+5V fused with self-resetting fuse)

PIN	P17A SIGNAL	PIN	P17B SIGNAL
1	+5V-USB2	2	+5V-USB3
3	USB2-	4	USB3-
5	USB2+	6	USB3+
7	Gnd-USB2	8	Gnd-USB3
9	NC	10	NC

Note:

- 1 – P17 odd pins are for USB2 and the even pins are USB3

P17A, P17B – Universal Serial Bus (USB) Connectors (I/O Bracket)

USB vertical connectors, Molex #6739-8001
 (+5V fused with self-resetting fuse)

PIN	P17A SIGNAL	PIN	P17B SIGNAL
1	+5V-USB0	1	+5V-USB1
2	USB0-	2	USB1-
3	USB0+	3	USB1+
4	Gnd-USB0	4	Gnd-USB1

Note:

- 1 – P17A is USB0 and P17B is USB1

P27, P28, P31, P32, P35, P36 – SATA II 300 Ports

7 pin vertical connector, Molex #67491-0031

PIN	SIGNAL	PIN	SIGNAL
1	Gnd	5	RX-
2	TX+	6	RX+
3	TX-	7	Gnd
4	Gnd		

Notes:

- 1 – P27 = SATA0 interface, P28 = SATA1 interface, P31 = SATA2 interface, P32 = SATA3 interface, P35 = SATA4 interface, P36 = SATA5 interface,
- 2 – SATA connectors support standard SATA II interface cables



Connectors (continued)

P2 and P19 – CPU Fan Power Connectors

3 pin single row header, Molex #22-23-2031

PIN	SIGNAL
------------	---------------

1	Gnd
2	+12V
3	Fan Tach

Note:

1 – P2 is the fan connector for CPU2 and P19 is for CPU1

P5 - SPEAKER PORT CONNECTOR

4 pin single row header, Amp #640456-4

PIN	SIGNAL
------------	---------------

1	Speaker Data
2	Key
3	Gnd
4	+5V

P6 - Reset Connector

2 pin single row header, Amp #640456-2

PIN	SIGNAL
------------	---------------

1	Gnd
2	Reset In

P12 – Hard Drive LED Connector

4 pin single row header, Amp #640456-4

PIN	SIGNAL
------------	---------------

1	LED +
2	LED -
3	LED -
4	LED +

P21 – POWER GOOD LED

2 pin single row header, Amp #640456-2

PIN	SIGNAL
------------	---------------

1	LED -
2	LED +



TRENTON Technology Inc.
 2350 Centennial Drive • Gainesville, Georgia 30504
 Sales (800) 875-6031 • Phone (770) 287-3100 • Fax (770) 287-3150

Connectors (continued)

P20 - I/O Expansion Mezzanine Card Connector (For IOBxx option modules)

76 pin controlled impedance connector, Samtec #MIS-038-01-FD-K

PIN	SIGNAL	PIN	SIGNAL
1	+12V	2	+5V_STANDBY
3	HDA_SDIN2	4	+5V_STANDBY
5	HDA_SDIN1	6	+5V_DUAL
7	HDA_SDIN0	8	+5V_DUAL
9	HDA_SYNC	10	HDA_BITCLK
11	HDA_SDOUT	12	HDA_ACRST
13	ICH_SMI#	14	ICH_RCIN#
15	ICH_SIOFME#	16	ICH_A2OGATE
17	Gnd	18	Gnd
19	L_FRAME#	20	L_AD3
21	L_DRQ1#	22	L_AD2
23	L_DRQ0#	24	L_AD1
25	SERIRQ	26	L_AD0
27	Gnd	28	Gnd
29	PCLK14SIO	30	PCLK33LPC
31	Gnd	32	Gnd
33	SMBDATA_RESUME	34	IPMB_DAT
35	SMBCLK_RESUME	36	IPMB_CLK
37	SALRT#_RESUME	38	IPMB_ALRT#
39	Gnd	40	Gnd
41	EXP_CLK100	42	EXP_RESET#
43	EXP_CLK100#	44	ICH_WAKE#
45	Gnd	46	Gnd
47	C_PE_TXP5	48	C_PE_RXP5
49	C_PE_TXN5	50	C_PE_RXN5
51	Gnd	52	Gnd
53	NC	54	NC
55	NC	56	NC
57	Gnd	58	Gnd
59	NC	60	NC
61	NC	62	NC
63	Gnd	64	Gnd
65	NC	66	NC
67	NC	68	NC
69	Gnd	70	Gnd
71	+3.3V	72	+5V
73	+3.3V	74	+5V
75	+3.3V	76	+5V

P3 – PCI Express Gen 2.0 Expansion Connector (For PEX10 option module)

80-pin (40 differential pairs) high-speed socket strip, Samtec #QSH-040-01-F-D-DP

PIN	SIGNAL	PIN	SIGNAL
Pins 1 to 8 = No Connection (NC)			
9	P1_PE_RXN15	10	P1_PE_TXN15
11	P1_PE_RXP15	12	P1_PE_TXP15
13	P1_PE_RXN14	14	P1_PE_TXN14
15	P1_PE_RXP14	16	P1_PE_TXP14
17	P1_PE_RXN13	18	P1_PE_TXN13
19	P1_PE_RXP13	20	P1_PE_TXP13
21	P1_PE_RXN12	22	P1_PE_TXN12
23	P1_PE_RXP12	24	P1_PE_TXP12
25	P1_PE_RXN11	26	P1_PE_TXN11
27	P1_PE_RXP11	28	P1_PE_TXP11
29	P1_PE_RXN10	30	P1_PE_TXN10
31	P1_PE_RXP10	32	P1_PE_TXP10
33	P1_PE_RXN9	34	P1_PE_TXN9
35	P1_PE_RXP9	36	P1_PE_TXP9
37	P1_PE_RXN8	38	P1_PE_TXN8
39	P1_PE_RXP8	40	P1_PE_TXP8
41	NC	42	NC
43	NC	44	NC
45	P1_PE_CFG2	46	P1_PE_CFG1
47	P1_GEN2_DSBL#	48	P1_PE_CFG0
49	P1_PE_RXN7	50	P1_PE_TXN7
51	P1_PE_RXP7	52	P1_PE_TXP7
53	P1_PE_RXN6	54	P1_PE_TXN6
55	P1_PE_RXP6	56	P1_PE_TXP6
57	P1_PE_RXN5	58	P1_PE_TXN5
59	P1_PE_RXP5	60	P1_PE_TXP5
61	P1_PE_RXN4	62	P1_PE_TXN4
63	P1_PE_RXP4	64	P1_PE_TXP4
65	P1_PE_RXN3	66	P1_PE_TXN3
67	P1_PE_RXP3	68	P1_PE_TXP3
69	P1_PE_RXN2	70	P1_PE_TXN2
71	P1_PE_RXP2	72	P1_PE_TXP2
73	P1_PE_RXN1	74	P1_PE_TXN1
75	P1_PE_RXP1	76	P1_PE_TXP1
77	P1_PE_RXN0	78	P1_PE_TXN0
79	P1_PE_RXP0	80	P1_PE_TXP0

NOTE: Need CPU2 installed for PCIe Gen 2.0 expansion



Memory

Each processor on the SHB supports three DDR3-1333 memory interfaces. There are six active Mini-DIMM sockets on the board and each one can support up to 32GB DIMMs for a total possible DDR3 system memory capacity of 192GB. However, currently available DDR3 Mini-DIMM memory capacities of 2GB, 4GB and 8GB are more common in today’s market; thereby, making the maximum practical limit of system memory supported 48GB. The peak memory interface bandwidth per channel is 32/GB/s when using PC3-10600 (i.e. DDR3-1333) Mini-DIMMs. Each of the direct CPU memory channel (BK##) terminates with a single in-line Mini-DIMM memory module socket. The System BIOS automatically detects memory type, size and speed.

Trenton recommends ECC registered DDR3 memory modules for use on the JXT6966 and these ECC registered (72-bit) DDR3 Mini-DIMMs must be PC3-10600 or PC3-8500 compliant. Unbuffered ECC DDR3 Mini-DIMMs are also supported on the JXT6966 SHB, but you cannot mix the two different memory types on the same board.

The SHB uses industry standard gold finger Mini-DIMM memory modules, which must be PC3-10600 or PC3-8500 compliant and have the following features:

- Gold-plated contacts
- ECC registered (72-bit) DDR3 memory
- 244-pin

The following Mini-DIMM sizes are supported:

MT/s	Mini-DIMM Type	Rank	Component Density
1333	PC3-10600	Single, Dual, Quad	1GB, 2GB, 4GB, 8GB, 12GB
1066	PC3-8500	Single, Dual, Quad	1GB, 2GB, 4GB, 8GB, 12GB

NOTE 1: To maximize memory interface speed, populate each memory channel with DDR3 Mini-DIMMs having the same interface speed. The SHB will support Mini-DIMMs with different speeds, but the memory channel interface will operate speed of the slowest Mini-DIMM.

NOTE 2: Low voltage (DDR3L) Mini-DIMMs are not supported.

NOTE 3: The SHB supports the following memory module memory latency timings:

- 6-6-6 for 800MHz DDR3 Mini-DIMMs
- 7-7-7 and 8-8-8 for 1066MHz DDR3 Mini-DIMMs
- 9-9-9 for 1333MHz DDR3 Mini-DIMMs

NOTE 4: Populating the memory sockets with Mini-DIMMs having different speeds is supported on the SHB; however, the overall memory interface speed will run at the speed of the slowest Mini-DIMM.

NOTE 5: Populate the memory sockets starting with the Mini-DIMM socket closest to the CPU and work your way toward the edges of the SHB as illustrated in the chart below:

Population order	CPU1	CPU2
1	BK00	BK10
2	BK01	BK11
3	BK02	BK12

[JXT6966 Product Detail](#)