

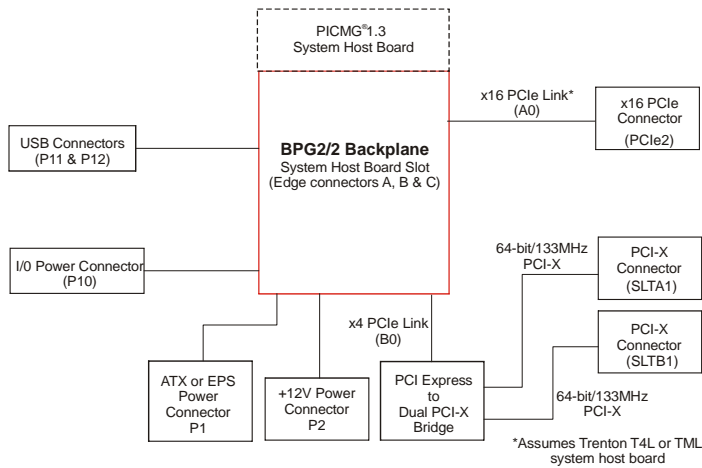

TRENTON Technology Inc.
 2350 Centennial Drive • Gainesville, Georgia 30504
 Sales (800) 875-6031 • Phone (770) 287-3100 • Fax (770) 287-3150

Technical Information – Jumpers and Connectors BPG2/2 (6532) Small Form Factor PCI Express Backplane

Block Diagram



Layout Diagram – 6532

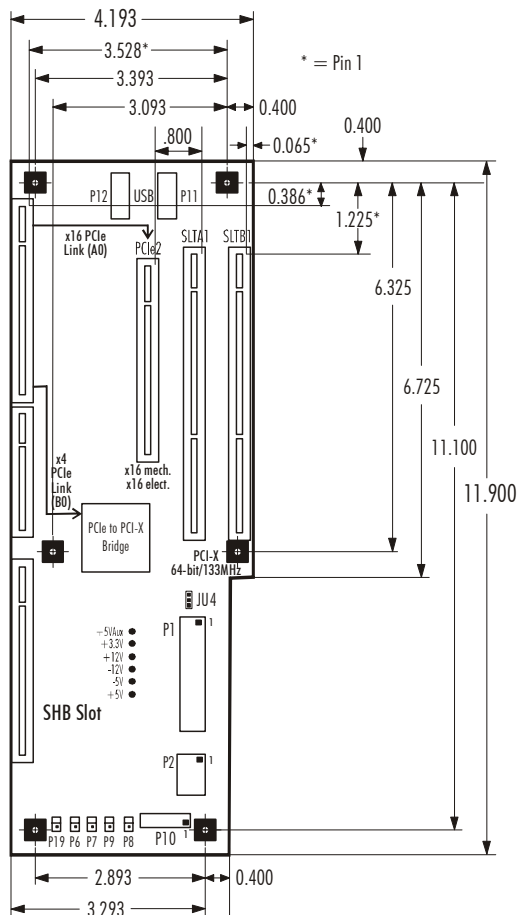

Notes:

**Optional USB connectivity provided by PICMG 1.3 SHB. Not all SHBs support this capability.

Connector spacing: 0.800"

Nominal PCB thickness: .062"

Mounting holes: .156" diameter

All dimensions are inches.



BPG2/2 (6532) Configuration Jumper

The setup of the configuration jumper on the backplane is described below. * indicates the default value of the jumper.

NOTE: For the two-position jumper (3-post), “TOP” and “BOTTOM” refer to positioning when the backplane is viewed with the slots at the top end of the backplane.

<u>Jumper</u>	<u>Description</u>
JU4	<p>+5V Auxiliary Voltage</p> <p>Install on the TOP if +5V auxiliary voltage is provided by the standard +5V supply. This option is used for systems which do not have either an ATX or EPS standard power input. This mode provides the necessary +5V for the SHB’s +5VAUX signal lines. Sleep mode recovery is not supported using non-ATX/EPS power supplies.</p> <p>Install on the BOTTOM if +5V auxiliary voltage is provided by a separate +5VAUX signal input pin. This enables the necessary SHB power signaling and allows recovery from sleep mode. This option is used for ATX or EPS standard power supplies. *</p>

BPG2/2 (6532) Connectors

The connectors available on the BPX3/2 vary depending on the version of the backplane you have. Connectors for the 6532-007 (right angle connectors) and 6532-008 (straight- in/vertical connectors) are defined below.

BPG2/2 (6532-007) Connectors

NOTE: Pin 1 on the connectors is indicated by the square pad on the PCB.

P1 - ATX/EPS Power Connector
 24 pin right angle dual row header, Amp #794516-1

<u>Pin</u>	<u>Signal</u>	<u>Pin</u>	<u>Signal</u>
1	+3.3V	13	+3.3V
2	+3.3V	14	-12V
3	Gnd	15	Gnd
4	+5V	16	PSO#
5	Gnd	17	Gnd
6	+5V	18	Gnd
7	Gnd	19	Gnd
8	PWRGD	20	-5V
9	+5VAUX	21	+5V
10	+12V	22	+5V
11	+12V	23	+5V
12	+3.3V	24	Gnd



BPG2/2 (6532-007) Connectors (continued)

P2 - +12V Power Connector

8 pin right angle mini fit JR, Molex #39-30-0080

<u>Pin</u>	<u>Signal</u>	<u>Pin</u>	<u>Signal</u>
1	Gnd	5	+12V
2	Gnd	6	+12V
3	Gnd	7	+12V
4	Gnd	8	+12V

P6 - Power-On Connector

2 pin right angle single row header, Molex #22-05-3021

<u>Pin</u>	<u>Signal</u>
1	PSO#
2	Gnd

P7 - Power Button Connector

2 pin right angle single row header, Molex #22-05-3021

<u>Pin</u>	<u>Signal</u>
1	PWRBT#
2	Gnd

P8 - Reset Connector

2 pin right angle single row header, Molex #22-05-3021

<u>Pin</u>	<u>Signal</u>
1	SHB_RST#
2	Gnd

P9 - Power Good Connector

2 pin right angle single row header, Molex #22-05-3021

<u>Pin</u>	<u>Signal</u>
1	PWRGD
2	Gnd

P10 - I/O Power Connector

20 pin right angle dual row header, Molex #87833-2020

<u>Pin</u>	<u>Signal</u>	<u>Pin</u>	<u>Signal</u>
1	Gnd	2	+12V
3	IPMB_DA	4	Gnd
5	IPMB_CL	6	+5V
7	SMDAT	8	+5VAUX
9	SMCLK	10	+3.3V
11	PWRBT#	12	PSO#
13	Gnd	14	SHB_RST#
15	PWRGD	16	+5VAUX
17	Gnd	18	+5VAUX
19	Gnd	20	-12V



BPG2/2 (6532-007) Connectors (continued)

P11 - Universal Serial Bus (USB) Connector

8 pin dual row header, Molex #702-46-0801
(+5V fused with self-resetting fuses)

<u>Pin</u>	<u>Signal</u>	<u>Pin</u>	<u>Signal</u>
1	+5V-USB0	2	+5V-USB1
3	USB0-	4	USB1-
5	USB0+	6	USB1+
7	Gnd-USB0	8	Gnd-USB1

P12 - Universal Serial Bus (USB) Connector

8 pin dual row header, Molex #702-46-0801
(+5V fused with self-resetting fuses)

<u>Pin</u>	<u>Signal</u>	<u>Pin</u>	<u>Signal</u>
1	+5V-USB2	2	+5V-USB3
3	USB2-	4	USB3-
5	USB2+	6	USB3+
7	Gnd-USB2	8	Gnd-USB3

P19 - System Management Bus Connector

2 pin right angle single row header, Molex #22-05-3021

<u>Pin</u>	<u>Signal</u>
1	SMB Clock
2	SMB Data

BPG2/2 (6532-008) Connectors

P1 - ATX/EPS Power Connector

24 pin dual row mini fit JR, Molex #39-29-6248

<u>Pin</u>	<u>Signal</u>	<u>Pin</u>	<u>Signal</u>
1	+3.3V	13	+3.3V
2	+3.3V	14	-12V
3	Gnd	15	Gnd
4	+5V	16	PSON#
5	Gnd	17	Gnd
6	+5V	18	Gnd
7	Gnd	19	Gnd
8	PWRGD	20	-5V
9	+5VAUX	21	+5V
10	+12V	22	+5V
11	+12V	23	+5V
12	+3.3V	24	Gnd

P2 - +12V Power Connector

8 pin mini fit JR, Molex #39-29-3086

<u>Pin</u>	<u>Signal</u>	<u>Pin</u>	<u>Signal</u>
1	Gnd	5	+12V
2	Gnd	6	+12V
3	Gnd	7	+12V
4	Gnd	8	+12V



BPG2/2 (6532-008) Connectors (continued)

P6 - Power-On Connector

2 pin right angle single row header, Molex #22-05-3021

<u>Pin</u>	<u>Signal</u>
1	PSO#
2	Gnd

P7 - Power Button Connector

2 pin right angle single row header, Molex #22-05-3021

<u>Pin</u>	<u>Signal</u>
1	PWRBT#
2	Gnd

P8 - Reset Connector

2 pin right angle single row header, Molex #22-05-3021

<u>Pin</u>	<u>Signal</u>
1	SHB_RST#
2	Gnd

P9 - Power Good Connector

2 pin right angle single row header, Molex #22-05-3021

<u>Pin</u>	<u>Signal</u>
1	PWRGD
2	Gnd

P10 - I/O Power Connector

20 pin right angle dual row header, Molex #87833-2020

<u>Pin</u>	<u>Signal</u>	<u>Pin</u>	<u>Signal</u>
1	Gnd	2	+12V
3	IPMB_DA	4	Gnd
5	IPMB_CL	6	+5V
7	SMDAT	8	+5VAUX
9	SMCLK	10	+3.3V
11	PWRBT#	12	PSO#
13	Gnd	14	SHB_RST#
15	PWRGD	16	+5VAUX
17	Gnd	18	+5VAUX
19	Gnd	20	-12V

P11 - Universal Serial Bus (USB) Connector

8 pin dual row header, Molex #702-46-0801

(+5V fused with self-resetting fuses)

<u>Pin</u>	<u>Signal</u>	<u>Pin</u>	<u>Signal</u>
1	+5V-USB0	2	+5V-USB1
3	USB0-	4	USB1-
5	USB0+	6	USB1+
7	Gnd-USB0	8	Gnd-USB1



BPG2/2 (6532-008) Connectors (continued)

P12 - Universal Serial Bus (USB) Connector

8 pin dual row header, Molex #702-46-0801
 (+5V fused with self-resetting fuses)

Pin	Signal	Pin	Signal
1	+5V-USB2	2	+5V-USB3
3	USB2-	4	USB3-
5	USB2+	6	USB3+
7	Gnd-USB2	8	Gnd-USB3

P19 - System Management Bus Connector

2 pin right angle single row header, Molex #22-05-3021

Pin	Signal
1	SMB Clock
2	SMB Data

Trenton SHB Optional Backplane I/O Support For the BPG2/2

TRENTON SHB	ETHERNET*			USB							
	LAN 0	LAN 1	LAN 2	USB 0	USB 1	USB 2	USB 3	USB 4	USB 5	USB 6	USB 7
TQ9 ^{1,4}	-	-	X	-	-	-	-	X	X	X	X
T4L ^{1,2}	-	-	X	-	-	-	-	X	X	X	X
TML ^{1,2}	-	-	X	-	-	-	-	X	X	X	X
MCG-series ³	-	-	X	-	-	-	-	X	X	X	X

* The BPG2/2 does not support the optional PICMG 1.3 backplane Ethernet interfaces

¹ LAN2 is a 10/100BASE-T Ethernet interface when using the TQ9, T4L or TML

² Backplane routings of USB interfaces 4 & 5 are factory build options on the T4L and TML

³ LAN2 is a 10/100/1000BASE-T Ethernet interface when using a MCG-series SHB

⁴ USB interfaces 4, 5, 6 and 7 are logical USB interfaces 8, 9, 10 and 11 on the TQ9 system host board

Note: The letter X indicates an interface connection routed to SHB edge connector C for use on the backplane.

Connector Configuration Illustrated For The BPG2/2

MODEL#	MODEL NAME	DESCRIPTION
6532-007	BPG2/2-CRA	ATX/EPS right-angle connectors
6532-008	BPG2/2-CST	ATX/EPS vertical connectors