

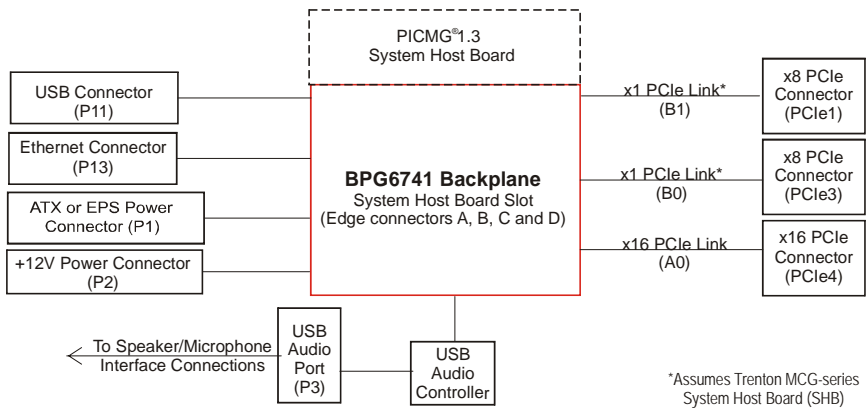

TRENTON Technology Inc.
 2350 Centennial Drive • Gainesville, Georgia 30504
 Sales (800) 875-6031 • Phone (770) 287-3100 • Fax (770) 287-3150

Technical Information – Jumpers and Connectors BPG6741 (6741) 2U Graphics-Class PCI Express Backplane

Block Diagram



Layout Diagram – 6741-007 and 6741-027

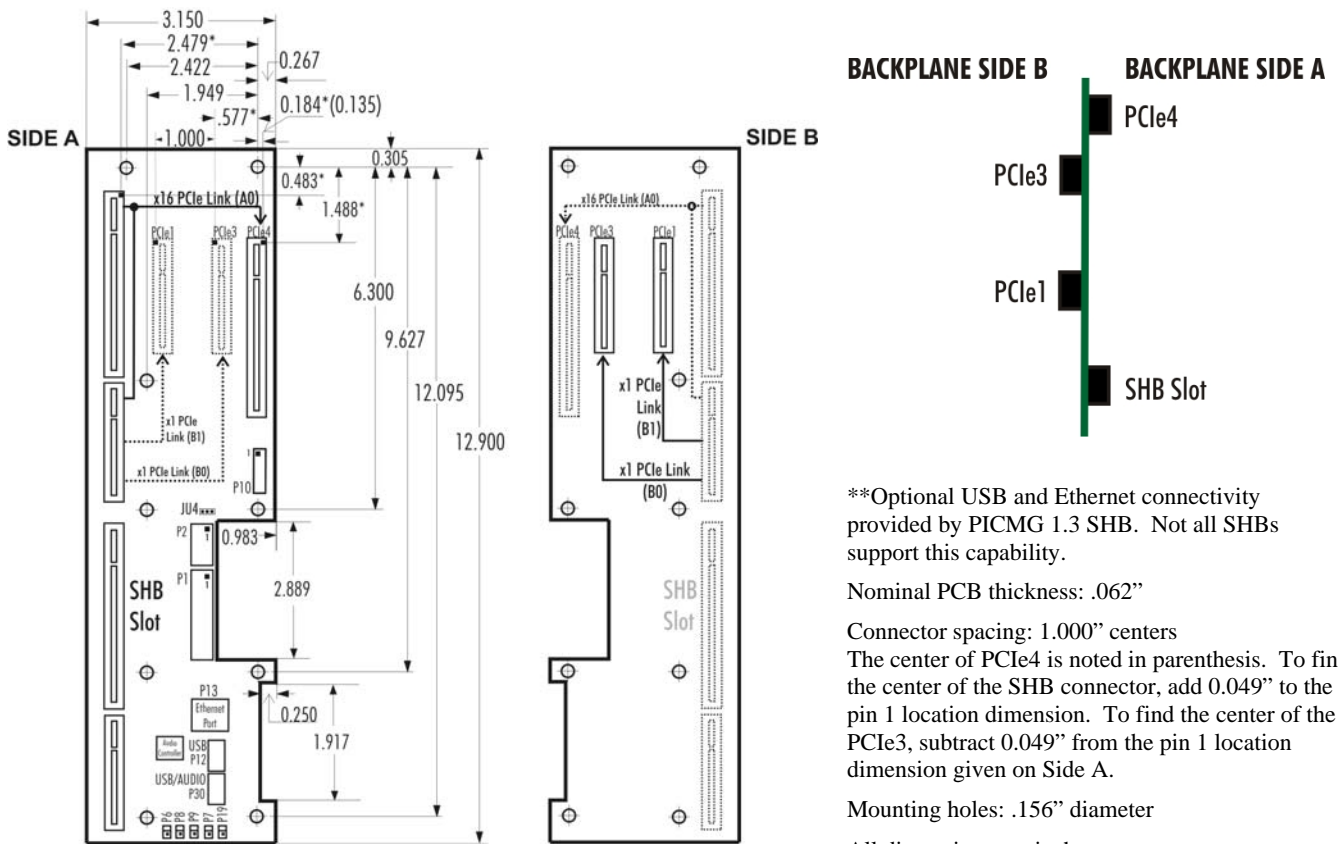



BPG6741 (6741-007 and 6741-027) Configuration Jumper

The setup of the configuration jumper on the backplane is described below. * indicates the default value of the jumper.

NOTE: For the two-position jumper (3-post), “RIGHT” and “LEFT” refer to positioning when the backplane is viewed with the slots at the top end of the backplane.

<u>Jumper</u>	<u>Description</u>
JU4	+5V Auxiliary Voltage
	Install on the LEFT if +5V auxiliary voltage is provided by the standard +5V supply. This option is used for systems which do not have either an ATX or EPS standard power input. This mode provides the necessary +5V for the SHB’s +5VAUX signal lines. Sleep mode recovery is not supported using non-ATX/EPS power supplies.
	Install on the RIGHT if +5V auxiliary voltage is provided by a separate +5VAUX signal input pin. This enables the necessary SHB power signaling and allows recovery from sleep mode. This option is used for ATX or EPS standard power supplies. *

BPG6741 (6741-007 and 6741-027) Connectors

NOTE: Pin 1 on the connectors is indicated by the square pad on the PCB.

P1 - ATX/EPS Power Connector
 24 pin right angle dual row, Molex #39-30-1240

<u>Pin</u>	<u>Signal</u>	<u>Pin</u>	<u>Signal</u>
1	+3.3V	13	+3.3V
2	+3.3V	14	-12V
3	Gnd	15	Gnd
4	+5V	16	PSO#
5	Gnd	17	Gnd
6	+5V	18	Gnd
7	Gnd	19	Gnd
8	PWRGD	20	-5V
9	+5VAUX	21	+5V
10	+12V	22	+5V
11	+12V	23	+5V
12	+3.3V	24	Gnd

P2 - +12V Power Connector
 8 pin right angle dual row, Molex #39-30-0080

<u>Pin</u>	<u>Signal</u>	<u>Pin</u>	<u>Signal</u>
1	Gnd	5	+12V
2	Gnd	6	+12V
3	Gnd	7	+12V
4	Gnd	8	+12V



BPG6741 (6741-007 and 6741-027) Connectors (continued)

P6 - Power-On Connector

2 pin right angle single row header, Molex #22-05-3021

<u>Pin</u>	<u>Signal</u>
1	PERSON#
2	Gnd

P7 - Power Button Connector

2 pin right angle single row header, Molex #22-05-3021

<u>Pin</u>	<u>Signal</u>
1	PWRBT#
2	Gnd

P8 - Reset Connector

2 pin right angle single row header, Molex #22-05-3021

<u>Pin</u>	<u>Signal</u>
1	SHB_RST#
2	Gnd

P9 - Power Good Connector

2 pin right angle single row header, Molex #22-05-3021

<u>Pin</u>	<u>Signal</u>
1	PWRGD
2	Gnd

P10 - I/O Power Connector

20 pin right angle dual row header, Molex #87833-2020

<u>Pin</u>	<u>Signal</u>	<u>Pin</u>	<u>Signal</u>
1	Gnd	2	+12V
3	IPMB_DA	4	Gnd
5	IPMB_CL	6	+5V
7	SMDAT	8	+5VAUX
9	SMCLK	10	+3.3V
11	PWRBT#	12	PERSON#
13	Gnd	14	SHB_RST#
15	PWRGD	16	5VAUX
17	GND	18	5VAUX
19	GND	20	-12V

P11 - Universal Serial Bus (USB) Connector

10 pin right angle dual row header, 3M, #N2510-5002UB
 (+5V fused with self-resetting fuses)

<u>Pin</u>	<u>Signal</u>	<u>Pin</u>	<u>Signal</u>
1	+5V-USB0	2	+5V-USB1
3	USB0-	4	USB1-
5	USB0+	6	USB1+
7	Gnd-USB0	8	Gnd-USB1
9	Chassis Gnd	10	Chassis Gnd



BPG6741 (6741-007 and 6741-027) Connectors (continued)

P13 - 10/100/1000Base-T Ethernet Connector - LAN 0 (6741-027 only)

8 pin right angle shielded RJ-45 connector, Molex #43860-0025

Pin Signal

1	TRP1+
2	TRP1-
3	TRP2+
4	TRP3+
5	TRP3-
6	TRP2-
7	TRP4+
8	TRP4-

P19 - SMBUS Connector

2 pin right angle single row header, Molex #22-05-3021

Pin Signal

1	SMBUS
2	Gnd

P30 - Universal Serial Bus (USB) Audio Connector

10 pin right angle dual row header, 3M, #N2510-5002UB

<u>Pin</u>	<u>Signal</u>	<u>Pin</u>	<u>Signal</u>
1	LineIn Lt.	2	LineIn Rt.
3	Gnd	4	Gnd
5	Mic P	6	Mic In
7	Gnd	8	Gnd
9	Linout Lt.	10	LineOut Rt.



BPG6741 Mechanical Clearance Chart – Option Card Slots

TRENTON	PCIe4 CARD LENGTH				PCIe3 CARD LENGTH				PCIe1 CARD LENGTH			
	Full	¾	½	¼	Full	¾	½	¼	Full	¾	½	¼
SHB	NR	NR	OK	OK	OK	OK	OK	OK	OK	OK	OK	OK
TQ9	NR	NR	OK	OK	OK	OK	OK	OK	OK	OK	OK	OK
T4L	NR	NR	OK	OK	OK	OK	OK	OK	OK	OK	OK	OK
TML	OK	OK	OK	OK	OK	OK	OK	OK	OK	OK	OK	OK
MCG-series	NR	NR	OK	OK	OK	OK	OK	OK	OK	OK	OK	OK

Note: The letters NR indicates that this card length is Not Recommended for use in the option card slot with the specific Trenton SHB

Trenton Server-Class SHB Optional Backplane I/O Support For the BPG6741

TRENTON	ETHERNET				USB							
	LAN0	LAN1	LAN2	USB0	USB1	USB2	USB3	USB4	USB5	USB6	USB7	
SHB	-	-	X	-	-	-	-	AUDIO	X	X	X	
TQ9 ^{1,4}	-	-	X	-	-	-	-	AUDIO	X	X	n/a	
T4L ^{1,2}	-	-	X	-	-	-	-	AUDIO	X	X	n/a	
TML ^{1,2}	-	-	X	-	-	-	-	AUDIO	X	X	n/a	
MCG-series ³	-	-	X	-	-	-	-	AUDIO	X	X	X	

¹ LAN2 is a 10/100BASE-T Ethernet interface when using the TQ9, T4L or TML

² Backplane routings of USB interfaces 4 & 5 are factory build options on the T4L and TML and must be ordered to enable backplane audio controller functionality

³ LAN2 is a 10/100/1000BASE-T Ethernet interface when using a MCG-series SHB

⁴ USB interfaces 4, 5, 6 and 7 are logical USB interfaces 8, 9, 10 and 11 on the TQ9 system host board

Note: The letter X indicates an interface connection routed to SHB edge connector C for use on the backplane