

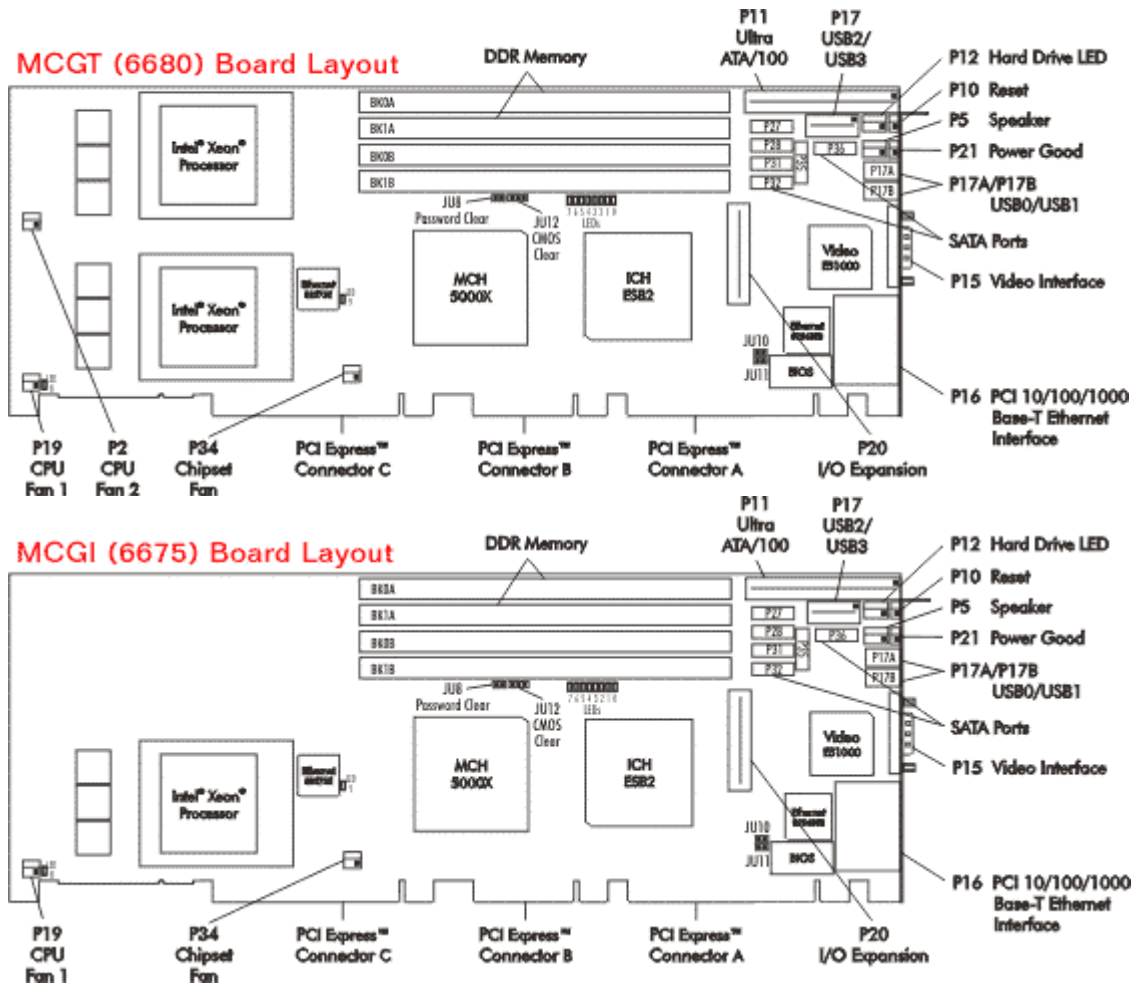

TRENTON Technology Inc.
2350 Centennial Drive • Gainesville, Georgia 30504
Sales (800) 875-6031 • Phone (770) 287-3100 • Fax (770) 287-3150

Technical Information – Jumpers, Connectors and Memory MCG Series (6680-, 6675-, 6690-, 6695-xxx) System Host Board

Layout Diagram



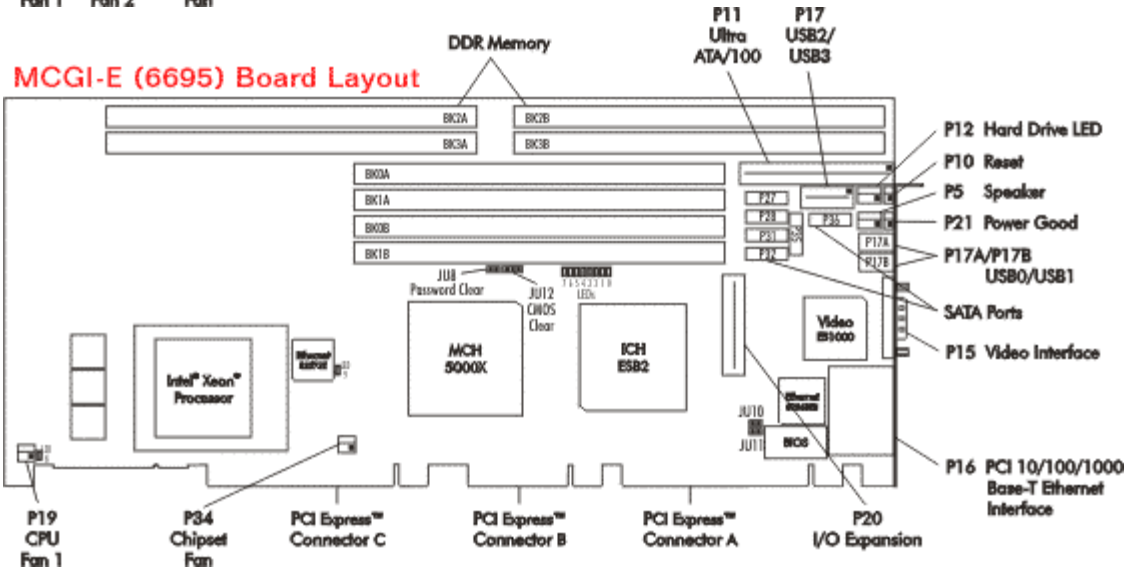
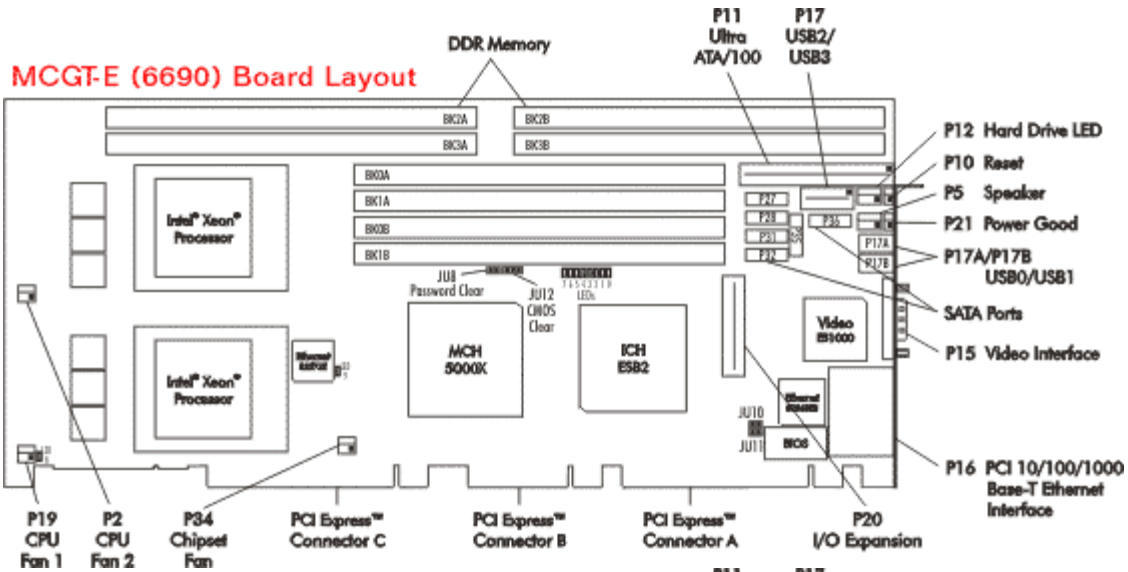

Jumpers & LEDs

The setup of the configuration jumpers on the SHB is described below. An asterisk (*) indicates the default value of each jumper.

NOTE: For two-position jumpers (3-post), "RIGHT" is toward the bracket end of the board; "LEFT" is toward the processor.

JU8 Password Clear

Install for one power-up cycle to reset the password to the default (null password).
 Remove for normal operation. *

JU10/11 System Flash ROM Operational Modes

The Flash ROM has two programmable sections: the Boot Block for "flashing" in the BIOS and the Main Block for the executable BIOS and PnP parameters. Normally only the Main Block is updated when a new BIOS is flashed into the system.

	JU10	JU11
All Blocks Write Enabled	Remove *	Remove *



Boot Block Write Protected	Install	Remove
Block 2-16 Write Protected	Remove	Install

JU12 CMOS Clear

Install on the RIGHT to clear.
 Install on the LEFT to operate. *

NOTE: To clear the CMOS, power down the system and install the jumper on the RIGHT. Wait for at least two seconds, move the jumper back to the LEFT and turn the power on. When AMIBIOS displays the "CMOS Settings Wrong" message, press F1 to go into the BIOS Setup Utility, where you may reenter your desired BIOS settings, load optimal defaults or load failsafe defaults.

Jumpers & LEDs (continued)

P1 Ethernet LEDs

I/O bracket connector P1 consists of two RJ-45 network connectors for Ethernet LAN1 and LAN2. Each LAN interface connector has two LEDs that indicate activity status and Ethernet connection speed. Listed below are the possible LED conditions and status indications for LAN1 and LAN2:

LED/Connector	Description
Activity LED	Green LED which indicates network activity. This is the upper LED on the LAN connector (i.e., toward the memory sockets).
Off	No current network transmit or receive activity
On (flashing)	Indicates network transmit or receive activity.
Speed LED	Green LED which identifies the connection speed. This is the lower LED on the LAN connector (i.e., toward the edge connectors).
Off	Indicates a valid link at 1000-Mb/s
On	Indicates a valid link at 100-Mb/s.
RJ-45 Network Connectors	The RJ-45 network connector requires a Connectors category 5 (CAT5) unshielded twisted-pair (UTP) 2-pair cable for a 100-Mb/s network connection or a category 3 (CAT3) or higher UTP 2-pair cable for a 10-Mb/s network connection. A category 5e (CAT5e) or higher UTP 2-pair cable is recommended for a 1000-Mb/s (Gigabit) network connection.

Backplane LAN LED

The backplane LAN LED (LED11) is a green LED located near PCI Express edge connector C and directly above the lower left anchor of the MCH heat sink. This LED indicates the status of communication between the SHB and the backplane as shown below:

LED Status	Description
Off	Indicates the LAN is inactive and link communications have not been established.
On (flashing)	Indicates that data is being transferred between the SHB and the backplane.
On (solid)	Indicates the LAN has a valid link and is ready for data transfers.

Power On LED

The Power On LED (LED11) is a red LED located at the center bottom of the SHB and is used to indicate the presence of the VCC voltage needed by the MCXX's DDR memory. When the LED is on this indicates that VCC_DDR is present and at an acceptable level to drive the SHBs memory DIMMs.



TRENTON Technology Inc.
2350 Centennial Drive • Gainesville, Georgia 30504
Sales (800) 875-6031 • Phone (770) 287-3100 • Fax (770) 287-3150

POST Code LEDs

As the POST (Power On Self Test) routines are performed during boot-up, test codes are displayed on Port 80 POST code LEDs 1 through 8, which are located in the center of the board to the right of the processor and are numbered from top (1) to bottom (8). Refer to the board layout diagram for the exact location of the POST code LEDs.

These POST codes may be helpful as a diagnostic tool. Specific error codes are listed in Appendix A - BIOS Messages section of the MCXX Technical Reference Manual, along with a chart to interpret the LEDs into hexadecimal format.



Jumpers & LEDs (continued)

CPU Throttling LED

The CPU throttling LED (LED9), which is located in the upper left corner of the MCXX, indicates the status of CPU thermal shutdown, as shown below:

LED Status	Description
Off	Indicates the CPU is operating within acceptable thermal levels.
On (flashing)	Indicates the CPU is throttling down to a lower operating speed due to rising CPU temperature.
On (solid)	Indicates the CPU has reached the thermal shutdown threshold limit. The SHB is still operating, but a thermal shutdown may soon occur.

NOTE: When a thermal shutdown occurs, the LED will stay on in systems using non- ATX/EPS power supplies. The CPU will cease functioning, but power will still be applied to the SHB. In systems with ATX/EPS power supplies, the LED will turn off when a thermal shutdown occurs because system power is removed via the ACPI soft control power signal S5. In this case, all SHB LEDs will turn off; however, stand-by power will still be present.

Connectors

NOTE:

Pin 1 on the connectors is indicated by the square pad on the PCB.

P2 - CPU Fan 2

3 pin single row header, Molex #22-23-2031

PIN	SIGNAL
1	Gnd
2	+12V
3	FanTach

P19 - CPU Fan 1

3 pin single row header, Molex #22-23-2031

PIN	SIGNAL
1	Gnd
2	+12V
3	Fan Tach

P20 - I/O Expansion Mezzanine Card Connector

76 pin controlled impedance connector, Samtec #MIS-038-01-FD-K

PIN	SIGNAL	PIN	SIGNAL
1	+12V	2	+5V_STANDBY
3	NC	4	+5V_STANDBY
5	NC	6	+5V_DUAL
7	NC	8	+5V_DUAL
9	NC	10	NC
11	NC	12	NC
13	ICH_SMI#	14	ICH_RCIN#
15	ICH_SIOPME#	16	ICH_A20GATE
17	Gnd	18	Gnd
19	L_FRAME#	20	L_AD3
21	L_DRQ1#	22	L_AD2
23	L_DRQ0#	24	L_AD1

P5 - Speaker Port Connector

4 pin single row header, Amp #640456-4

PIN	SIGNAL
1	Speaker Data
2	Key
3	Gnd
4	+5V

P10 - External Reset Connector

2 pin single row header, Amp #640456-2

PIN	SIGNAL
1	External Reset In (Low Active)
2	Gnd



Connectors (Continued)

P11 - ATA/100 Hard Drive Connector

40 pin dual row header, Amp #1-1761610-3

PIN	SIGNAL	PIN	SIGNAL
1	Reset	2	Gnd
3	Data 7	4	Data 8
5	Data 6	6	Data 9
7	Data 5	8	Data 10
9	Data 4	10	Data 11
11	Data 3	12	Data 12
13	Data 2	14	Data 13
15	Data 1	16	Data 14
17	Data 0	18	Data 15
19	Gnd	20	NC
21	DRQ 0	22	Gnd
23	IOW	24	Gnd
25	IOR	26	Gnd
27	IORDY	28	SELPDP
29	DACK 0	30	Gnd
31	IRQ 14	32	NC
33	Add 1	34	PCBL DET*
35	Add 0	36	Add 2
37	CS 1P	38	CS 3P
39	IDEACTP	40	Gnd

* For ATA/66 and ATA/100 drives, which should be set for Cable Select for proper speed operation. If other Drives are detected, pin definition is Gnd.

P12 - Hard Drive LED Connector

4 pin single row header, Amp #640456-4

PIN	SIGNAL
1	LED +
2	LED -
3	LED -
4	LED +

25	SERIRQ	26	L_AD0
27	Gnd	28	Gnd
29	PCLK14SIO	30	PCLK33LPC
31	Gnd	32	Gnd
33	SMBDATA_RESUME	34	IPMB_DAT
35	SMBCLK_RESUME	36	IPMB_CLK
37	SALRT#_RESUME	38	IPMB_ALRT#
39	Gnd	40	Gnd
41	EXP_CLK100	42	EXP_RESET#
43	EXP_CLK100#	44	ICH_WAKE#
45	Gnd	46	Gnd
47	C_PE_TXP4	48	C_PE_RXP4
49	C_PE_TXN4	50	C_PE_RXN4
51	Gnd	52	Gnd
53	C_PE_TXP3	54	C_PE_RXP3
55	C_PE_TXN3	56	C_PE_RXN3
57	Gnd	58	Gnd
59	C_PE_TXP2	60	C_PE_RXP2
61	C_PE_TXN2	62	C_PE_RXN2
63	Gnd	64	Gnd
65	C_PE_TXP1	66	C_PE_RXP1
67	C_PE_TXN1	68	C_PE_RXN1
69	Gnd	70	Gnd
71	+3.3V	72	+5V
73	+3.3V	74	+5V
75	+3.3V	76	+5V

P21 - Power Good LED

2 pin single row header, Amp #640456-2

PIN	SIGNAL
1	LED -
2	LED +

P27 - SATA PORT 0

7 pin vertical connector, Molex #67491-0031



Connectors (Continued)

P15 - Video Interface Connector

15 pin HD15 connector, Kycon #K31X-E15S-N

PIN	SIGNAL	PIN	SIGNAL	PIN	SIGNAL
1	Red	6	Gnd	11	NC
2	Green	7	Gnd	12	EEDI
3	Blue	8	Gnd	13	HSYNC
4	NC	9	+5V	14	VSYNC
5	Gnd	10	Gnd	15	EECS

P16 - 10/100/1000Base-T Ethernet Connector - LAN1/LAN2

Dual RJ-45 connector, Pulse #JG0-0024NL Each individual RJ-45 connector is defined as follows:

PIN	SIGNAL
1	TRP1+
2	TRP1-
3	TRP2+
4	TRP3+
5	TRP3-
6	TRP2-
7	TRP4+
8	TRP4-

P17 - Universal Serial Bus (USB) Connector

8 pin dual row header, Molex #702-46-08-01 (+5V fused with self-resetting fuses)

PIN	SIGNAL	PIN	SIGNAL
1	+5V - USB2	2	+5V - USB3
3	USB2-	4	USB3-
5	USB2+	6	USB3+
7	Gnd - USB2	8	Gnd - USB3

P17A - Universal Serial Bus(USB) Connector

USB vertical connector, Molex #47500-0001 (+5V fused with self-resetting fuse)

PIN	SIGNAL
1	+5V - USB0

PIN	SIGNAL	PIN	SIGNAL
1	Gnd	5	RX-
2	TX+	6	RX+
3	TX-	7	Gnd
4	Gnd		

P28 - SATA PORT1

7 pin vertical connector, Molex #67491-0031

PIN	SIGNAL	PIN	SIGNAL
1	Gnd	5	RX-
2	TX+	6	RX+
3	TX-	7	Gnd
4	Gnd		

P31 - SATA PORT2

7 pin vertical connector, Molex #67491-0031

PIN	SIGNAL	PIN	SIGNAL
1	Gnd	5	RX-
2	TX+	6	RX+
3	TX-	7	Gnd
4	Gnd		

P32 - SATA PORT3

7 pin vertical connector, Molex #67491-0031

PIN	SIGNAL	PIN	SIGNAL
1	Gnd	5	RX-
2	TX+	6	RX+
3	TX-	7	Gnd
4	Gnd		

P34 - Chipset Fan

3 pin single row header, Molex #22-23-2031

PIN	SIGNAL
1	Gnd
2	+12V
3	FanTach



- 1 +5V - USB0
- 2 USB0-
- 3 USB0+
- 4 Gnd - USB0

P35 - SATA PORT4

7 pin vertical connector, Molex #67491-0031

PIN	SIGNAL	PIN	SIGNAL
1	Gnd	5	RX-
2	TX+	6	RX+
3	TX-	7	Gnd
4	Gnd		

Connectors (Continued)

P17B - Universal Serial Bus(USB) Connector

USB vertical connector, Molex #47500-0001
 (+5V fused with self-resetting fuses)

PIN	SIGNAL
1	+5V - USB1
2	USB1-
3	USB1+
4	Gnd - USB1

P36 - SATA PORT5

7 pin vertical connector, Molex #67491-0031

PIN	SIGNAL
1	Gnd
2	TX+
3	TX-
4	Gnd

Memory

The four-channel Double Data Rate (DDR2) memory interface on the MCXT and MCXI SHBs supports up to 16GB of Fully Buffered DIMM (FB-DIMM) memory; the MCXT-E and MCXI-E models support up to 32GB of FB-DIMM memory.

FB-DIMMs have "Advanced Memory Buffer" chips that provide enhanced signal integrity and improved error detection that help reduce soft memory errors. FB-DIMM memory technology improves overall system reliability by extending the current ECC capability to include protection of command and address data. FD-DIMMs feature automatic retries when a memory error is detected, which results in uninterrupted system operation in the event of transient errors.

An MCX-series SHB uses industry standard 72-bit wide ECC gold finger FB-DIMM memory modules in four (MCXT/MCXI) or eight (MCXT-E/MCXI-E) 240-pin sockets. The FB-DIMMs must be PC2-4200 or PC2-5300 (DDR2-533 or DDR2-667) and comply with the JEDEC Rev. 2.0 specifications.

The following dual-rank FB-DIMM sizes are supported:

FB-DIMM Size	DIMM Type	ECC
512MB	Registered	64M x 72
1GB	Registered	128M x 72
2GB	Registered	256M x 72
4GB	Registered	512M x 72



A minimum of one 512MB FB-DIMM is required and must be populated in DIMM socket BK0A.

NOTE: With the bracket end of the board to the right, the four FB-DIMM sockets available on the MCXT and MCXI SHBs are numbered BK0A, BK1A, BK0B and BK1B, from top to bottom. On the extended-memory MCXT-E and MCXI-E SHBs, there are an additional four FB-DIMM sockets. The upper sockets are BK2A and BK2B, from left to right, and the lower sockets are BK3A and BK3B. These socket definitions are illustrated in the board layouts. All memory modules must have gold contacts.

NOTE: To maximize memory interface speed and bandwidth, and to take full advantage of the four-channel memory interface of the SHB's memory controller hub, the FB-DIMMs in socket banks 0A and 1A must be identical with respect to manufacturing, speed, timing and organization. Likewise, FB-DIMMs used in sockets 0B and 1B must be identical. FB-DIMMs in socket banks contained within the same memory channel, i.e., 0A and 2A do not have to be identical.

A minimum of one 512MB FB-DIMM is required and must be populated in DIMM socket BK0A. When using more than one FB-DIMM, you must populate the memory sockets in multiples of two in order to maximize the speed and performance of the memory interface. The following table explains the DDR2 FB-DIMM population rules:

FB-DIMM POPULATION CONFIGURATION	FB-DIMM Sockets (MCXT, MCXE)				FB-DIMM Sockets (MCXT-E, MCXI-E)			
	BANK 0A	BANK 1A	BANK 0B	BANK 1B	BANK 2A	BANK 2B	BANK 3A	BANK 3B
Single Module	FB-DIMM	Empty	Empty	Empty	Empty	Empty	Empty	Empty
Two Modules	FB-DIMM	FB-DIMM	Empty	Empty	Empty	Empty	Empty	Empty
Four Modules	FB-DIMM	FB-DIMM	FB-DIMM	FB-DIMM	Empty	Empty	Empty	Empty
Six Modules	FB-DIMM	FB-DIMM	FB-DIMM	FB-DIMM	FB-DIMM	FB-DIMM	Empty	Empty
Eight Module	FB-DIMM	FB-DIMM	FB-DIMM	FB-DIMM	FB-DIMM	FB-DIMM	FB-DIMM	FB-DIMM